



---

# Fiber Optic Sensor Technology

Miao Yu

*Assistant Professor*

*Sensors and Actuators Laboratory*

*Department of Mechanical Engineering*

*University of Maryland, USA*

---

*IMAC XXVI, Orlando, FL*

*Feb 6, 2008*

# Introduction



## ❖ Fiber optic sensor systems

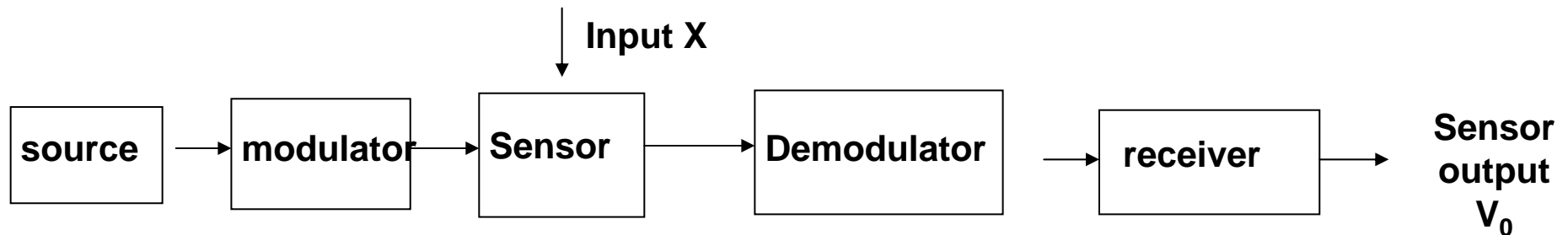

## ❖ Why fiber optic sensors?

- Harsh environment capability: *intensive EMI, high temperature, chemical corrosion, high pressure, high voltage*
- Light weight and small size
- Excellent performance: *high sensitivity and large bandwidth*
- Long range operation
- Multiplexed or distributed measurements

# Introduction



## ❖ Current applications

- Mechanical measurements: force, pressure, strain/stress, displacement, temperature, acceleration, vibration, acoustics
- Electrical and magnetic measurements
- Chemical and biological sensing



# Introduction



## ❖ Fiber Optic Sensor Classifications

- Sensing region: Intrinsic vs. Extrinsic
  - Intrinsic fiber optic sensor has a sensing region within the fiber and light never goes out of the fiber.
  - In extrinsic sensors, light has to leave the fiber and reach the sensing region outside and then comes back to the fiber.
  
- Optical modulation mechanism
  - Intensity modulated
  - Phase modulated
  - Wavelength modulated
  - Polarization modulated



---

# Intensity Modulated Fiber Optic Sensors

# Intensity Modulated Fiber Optic Sensors

## ❖ Basic structures

### ➤ Reflection type

- Source: broadband
- Fiber: multimode is better
- $P_{out} \propto L$
- Used as distance or pressure sensors

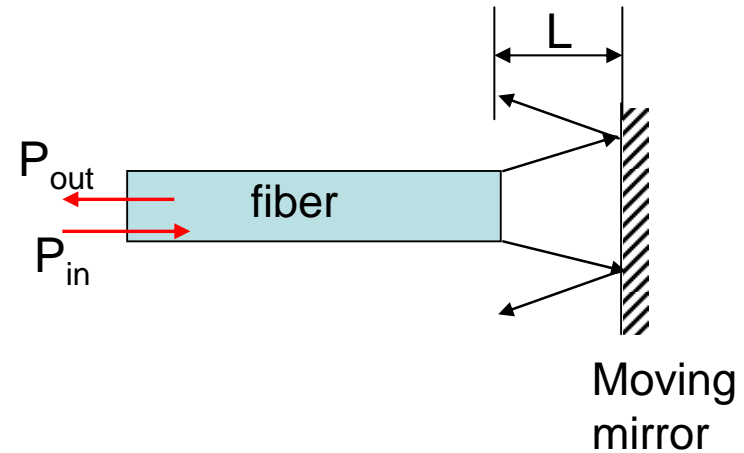

### ➤ Transmission type

- Similar to a movable reflector
- Used as strain or distance sensors

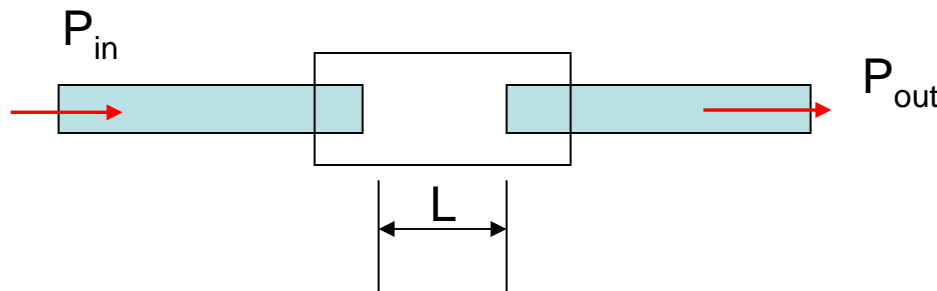

Limitation: no reference signal so it suffers from light source intensity fluctuation and fiber loss varies

# Intensity Modulated Fiber Optic Sensors

## ❖ Basic structures

### ➤ Differential intensity sensors

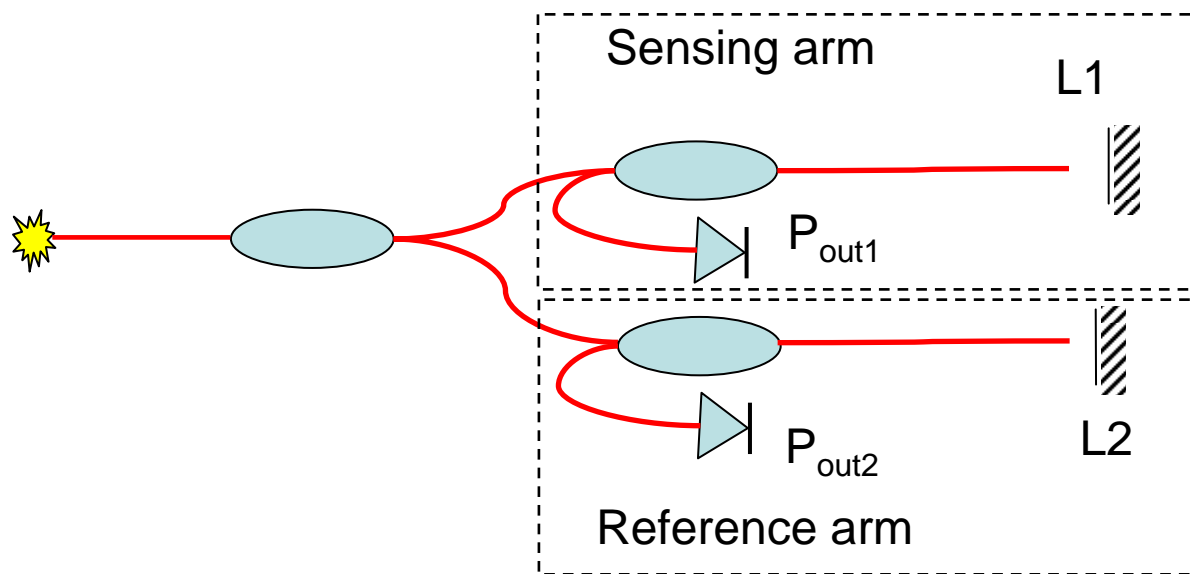

- Take care of the power fluctuation issue by using differential intensity signal from sensing arm and reference arm
- $P_{out1} - P_{out2} \propto L1 - L2$

# Intensity Modulated Fiber Optic Sensors

## ❖ Other intensity based sensors

### ➤ Microbending sensor

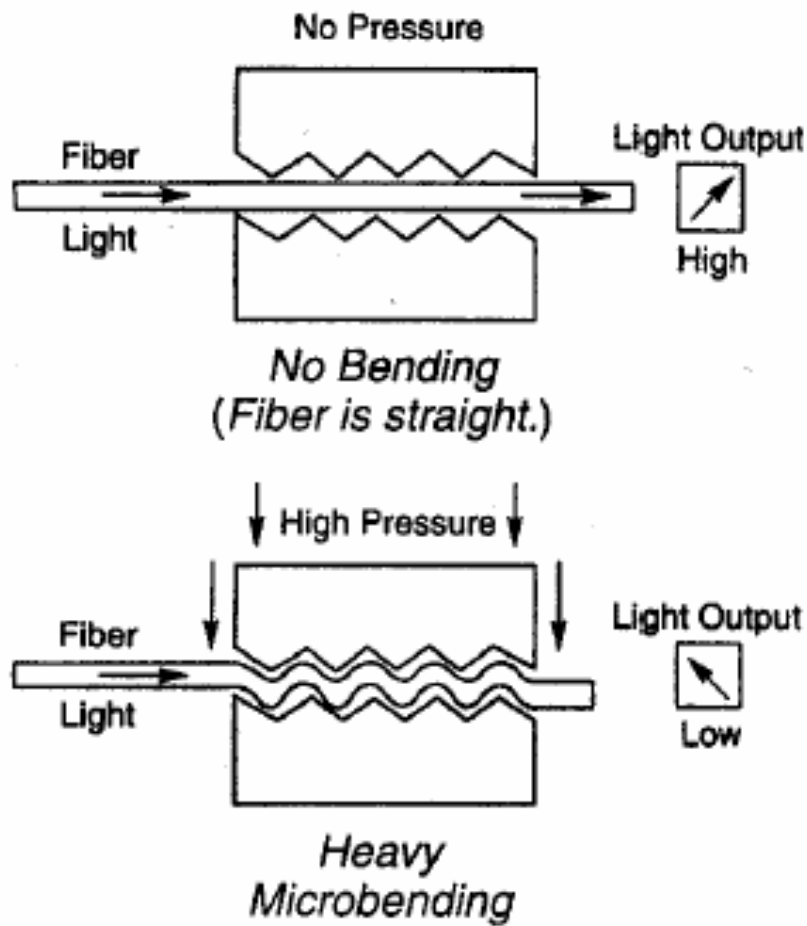

# Intensity Modulated Fiber Optic Sensors

## ❖ Other intensity based sensors

### ➤ Intensity based force sensor

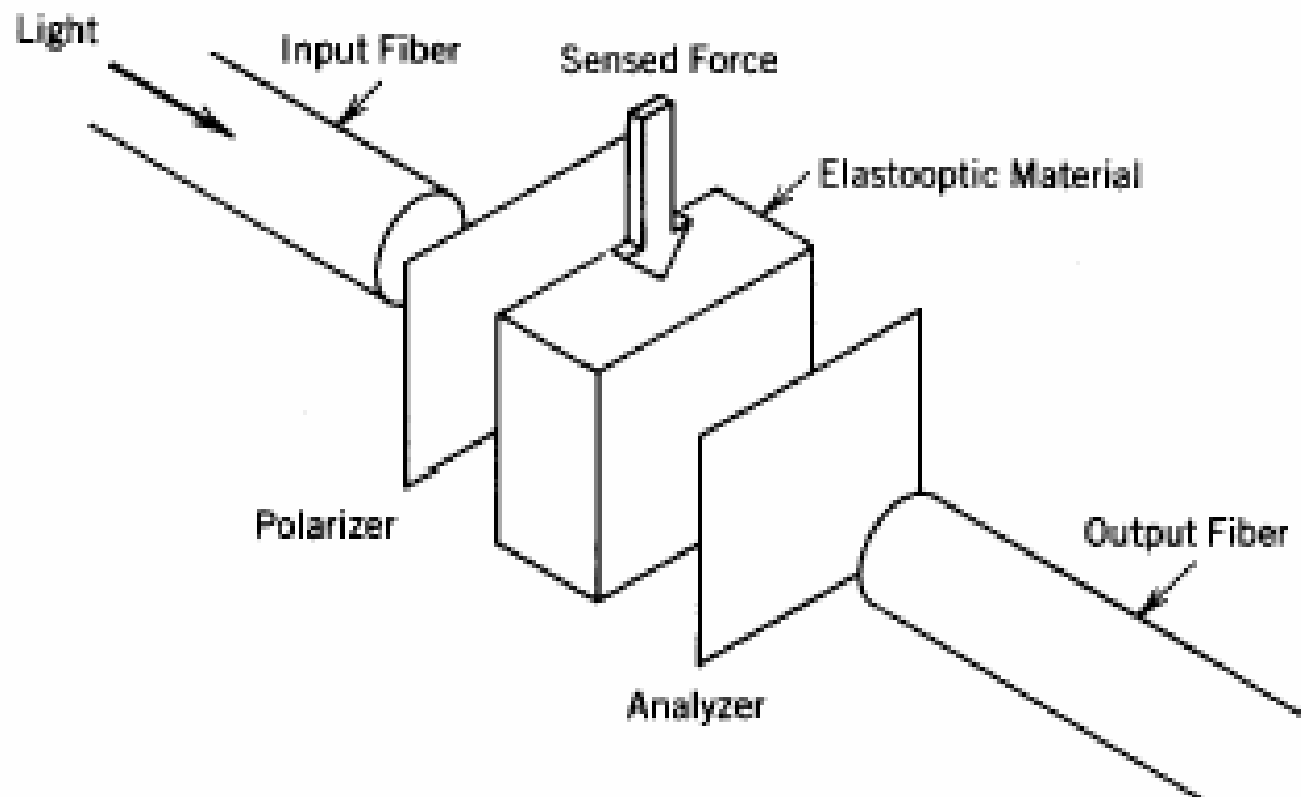

# Intensity Modulated Fiber Optic Sensors

---

- ❖ Properties of intensity based sensors
  - Versatile
  - Simple design and easy signal interpretation
  - Usually suffer from intensity fluctuations and low sensitivity



---

# Phase Modulated Fiber Optic Sensors

# Phase Modulated Fiber Optic Sensors

## ❖ Fiber Interferometers as sensors

Output of the sensor

$$I = A + B \cos \Delta\phi$$
$$\Delta\phi = k_0 OPD = \frac{2\pi}{\lambda} n \Delta L$$
$$\delta\Delta\phi = \frac{2\pi}{\lambda^2} OPD \delta\lambda + \frac{2\pi}{\lambda} n \delta\Delta L + \frac{2\pi}{\lambda} \Delta L \delta n$$

In an interferometer based sensor,  $\delta\lambda, \delta\Delta L, \delta n \rightarrow \delta\Delta\phi$

# Phase Modulated Fiber Optic Sensors

## Conventional fiber optic interferometers

### ❖ Two beam interferometer:

➤ Michelson interferometer

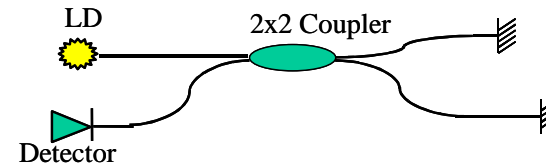

➤ Mach-Zehnder interferometer

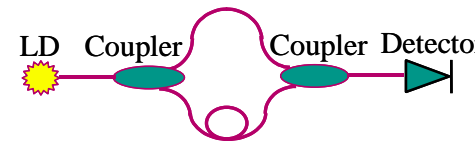

### ❖ Multi-beam interferometer

➤ Fabry-Perot interferometer

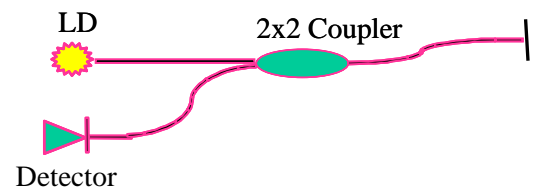

➤ Ring interferometer

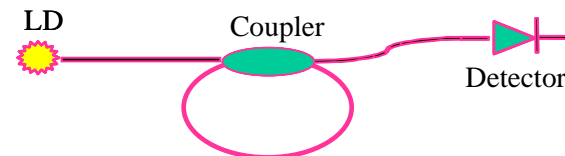

• Coherence light source:  
 $l_c \gg OPD$

❖ Properties: high sensitivity compared to intensity based sensors

# Phase Modulated Fiber Optic Sensors

- ❖ Low coherence fiber optic interferometer: use low coherence light source

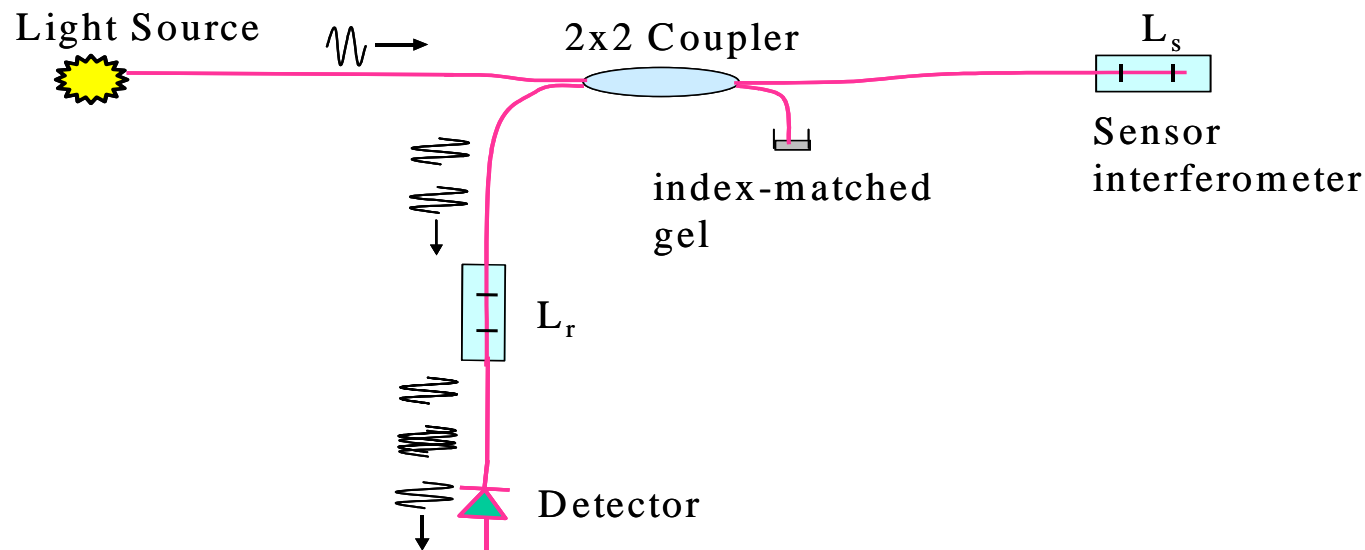

- Advantages: high sensitivity, large dynamic range, noise resistance

# Phase Modulated Fiber Optic Sensors

❖ **Two Beam Fiber Interferometers:** single mode fibers and coherence light source

• Michelson Interferometer

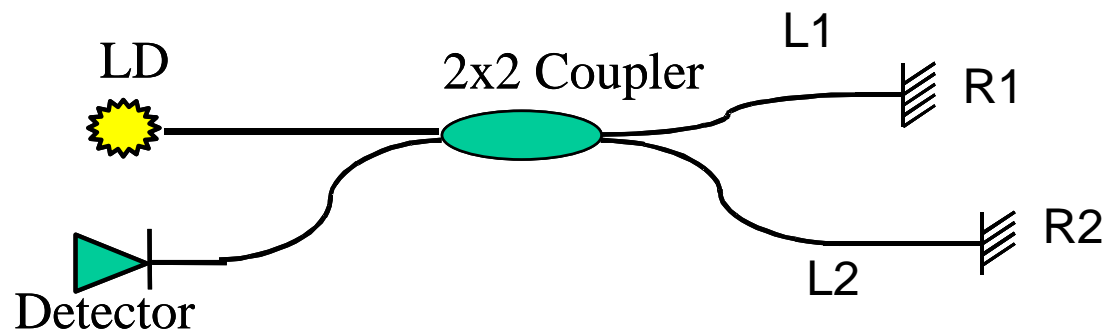

$$I = \frac{I_0}{4} (R_1 + R_2) \left[ 1 + 2 \frac{\sqrt{R_1 R_2}}{R_1 + R_2} \cos[2k(L_1 - L_2)] \right]$$

- fiber polarization states remain unchanged
- $OPD \ll l_c$
- coupler 50:50

# Phase Modulated Fiber Optic Sensors

## ❖ Two Beam Fiber Interferometers

• Mach-Zehnder Interferometer:  $OPD \ll l_c$

coupling ratio 50:50

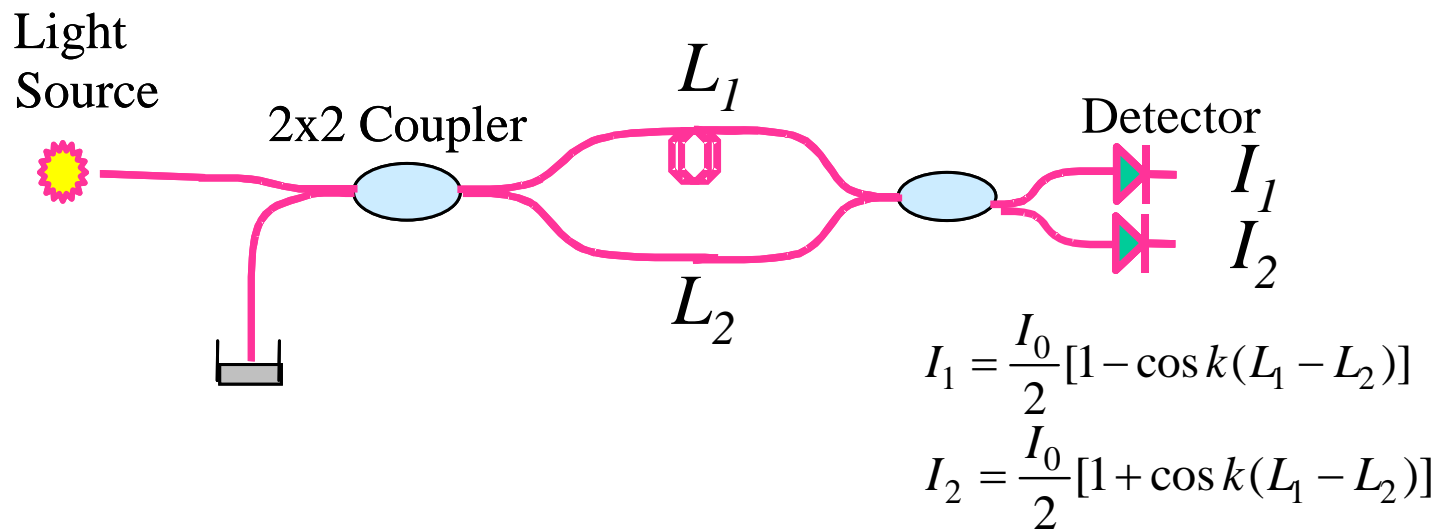

Advantages: a) reduce undesired feedback effect (no mirrors)  
b) reduce noise due to intensity fluctuations

$$\frac{I_1 - I_2}{I_1 + I_2}$$

# Phase Modulated Fiber Optic Sensors

- Quadrature point and sensor operation point:

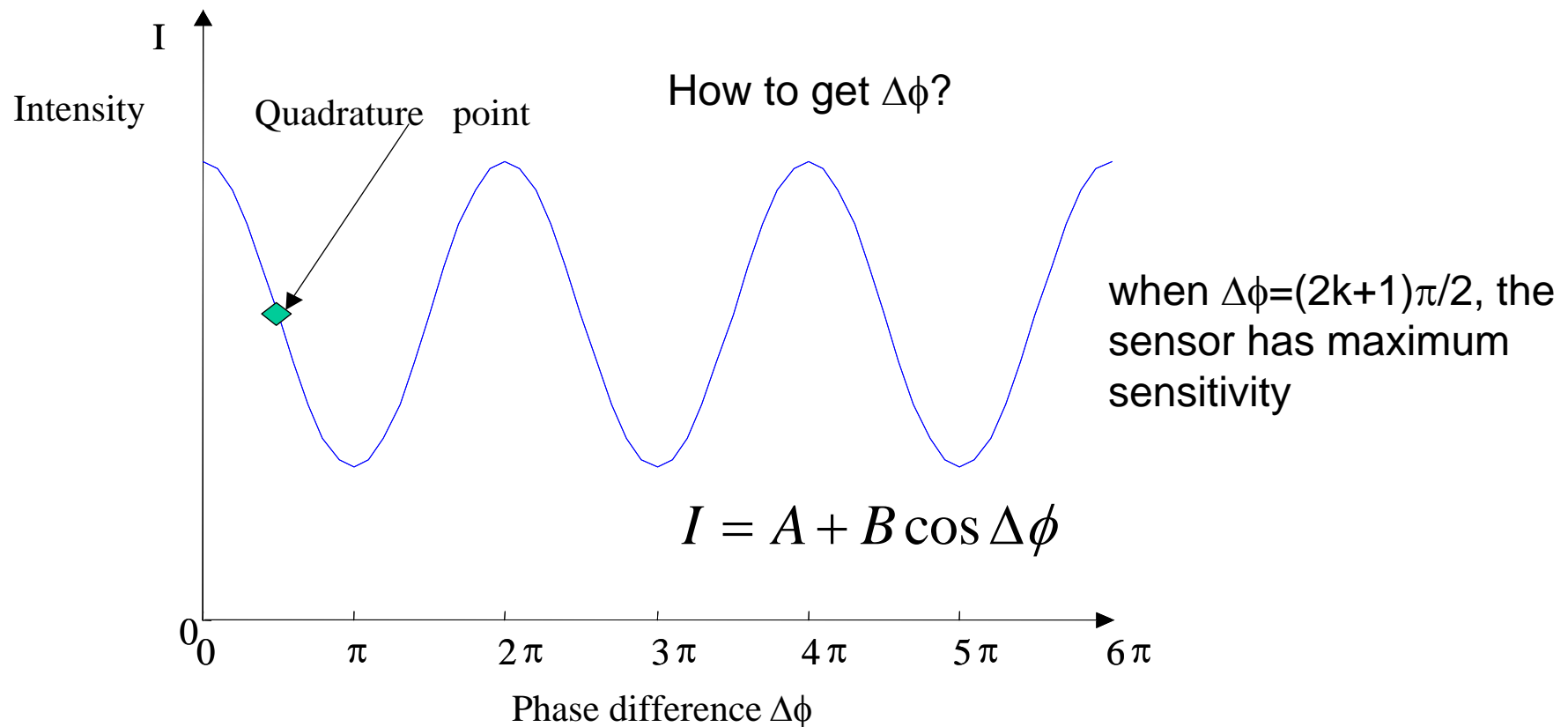

**Properties:** highly sensitive but sensitive to wavelength fluctuations and sometime with limited dynamic range

# Phase Modulated Fiber Optic Sensors

---

## ❖ Phase Demodulation Techniques

- Passive demodulation: without phase modulation
- Active demodulation: with feedback control or/and phase modulation
  
- Homodyne: optical frequency in the two arms of the fiber optic interferometer are the same
- Heterodyne: optical frequency in the two arms of the fiber optic interferometer are different

Passive homodyne, active homodyne, and heterodyne

# Phase Modulated Fiber Optic Sensors

## ❖ Two Beam Fiber Interferometer sensors

• **Applications** : strain/stress, temperature, pressure, acoustic, current/voltage, and much more.

Anti Submarine Warfare Fiber Optic Passive Sonar (from Northrop Grumman)



- acoustic and seismic monitoring applications
- Michelson or Mach-Zehnder interferometers
- Arrays can be composed of fully connectorized modules with more than 50 single mode fiber sensors



# Phase Modulated Fiber Optic Sensors

## Mach-Zehnder Fiber Optic Hydrophone 120 - 140 dB Dynamic Range

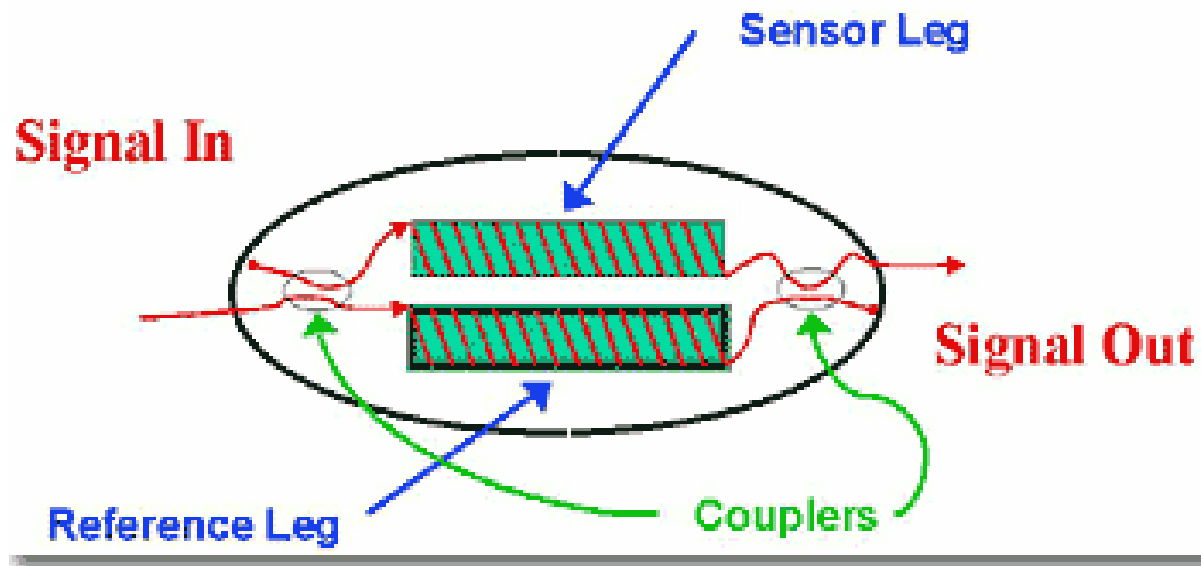

- Pressure changes are measured by the change in diameter of a hollow mandrel on the sensing leg of a Mach-Zehnder interferometer.
- This hydrophone configuration achieves 120 to 140-dB dynamic range (Courtesy Litton Guidance and Control Systems).

# Phase Modulated Fiber Optic Sensors

## ❖ Two Beam Fiber Interferometer sensors

### • Applications

Deformation Monitoring (Intelligent inspection company in Japan)

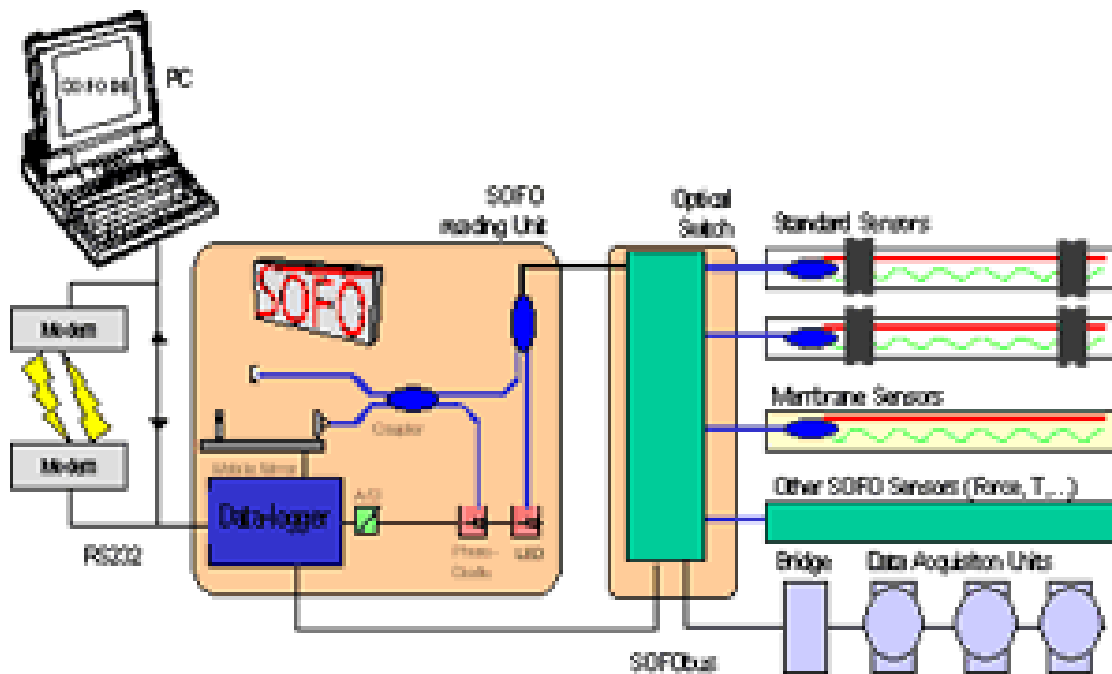

Deformation measurement of a concrete bridge deck

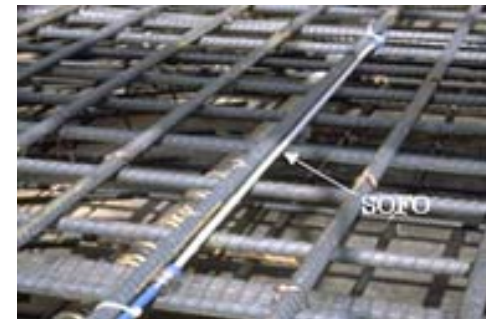

Embedded in concrete

# Phase Modulated Fiber Optic Sensors

## ❖ Multi-Beam Fiber Interferometers

### ➤ Fabry-Perot (FP) interferometer

- Conventional FP interferometer uses coherent light source
- Can realize extremely small cavity length (or OPD)
- Sensor structure

#### • Extrinsic

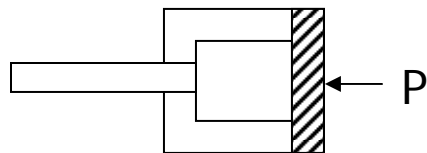

#### • Intrinsic

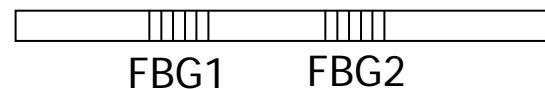
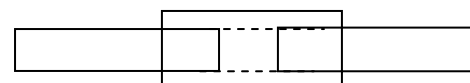
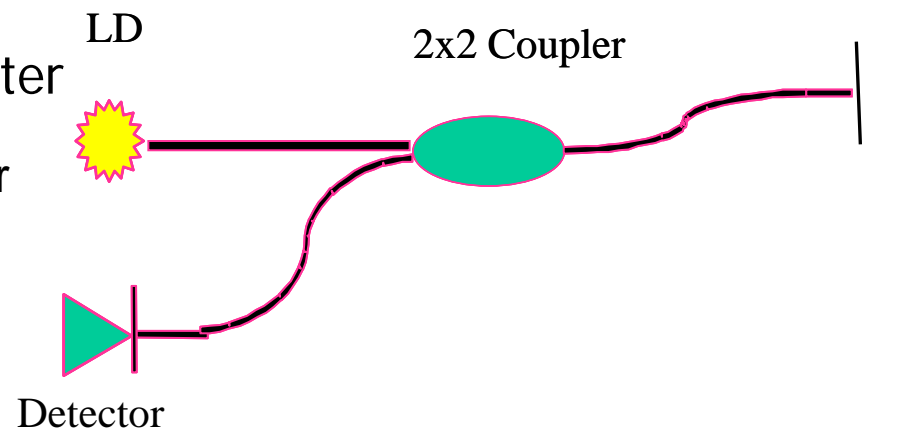
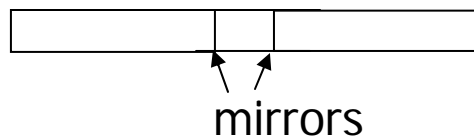

# Phase Modulated Fiber Optic Sensors

## ❖ Multi-beam Fiber Interferometers

- Fabry-Perot interferometer

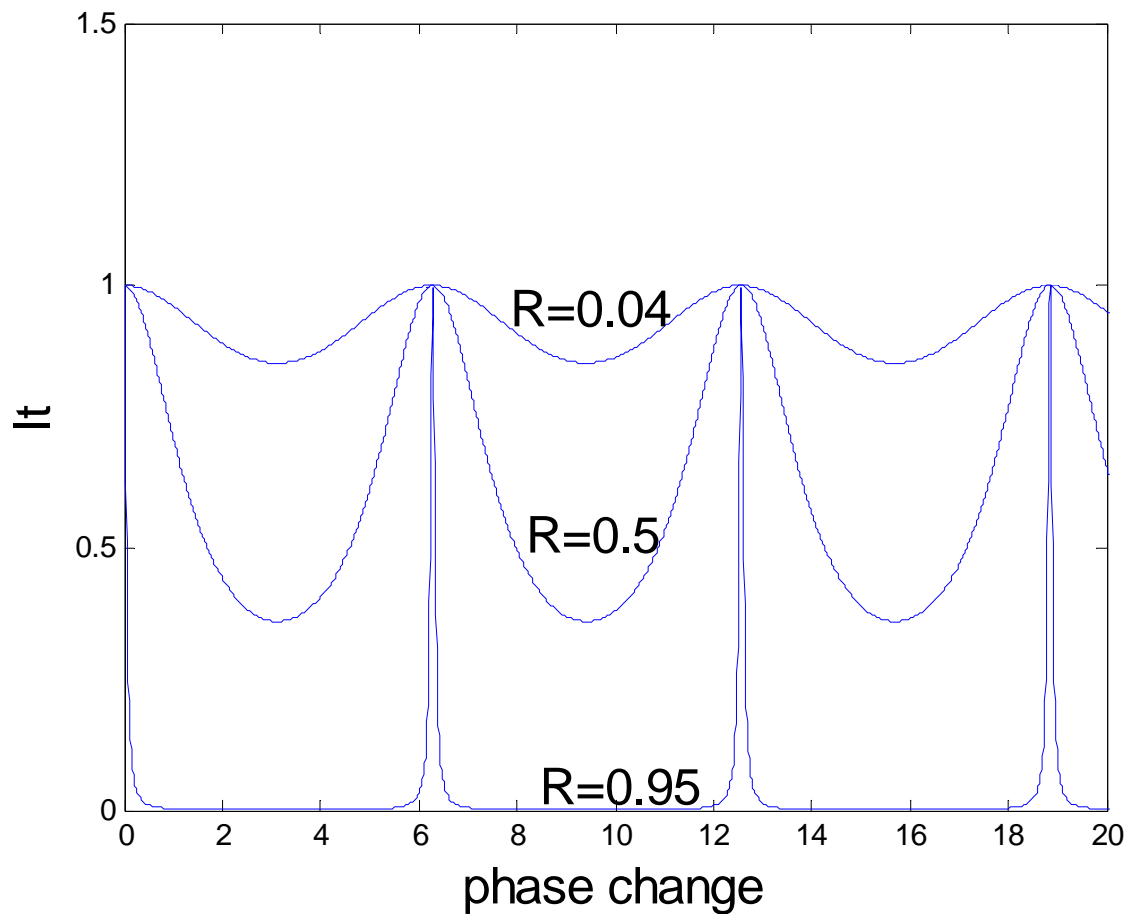

when  $R_a = R_b = R$      $\Delta\phi=2kL$

$$I_t = E_t \cdot E_t^* = I_0 \frac{1}{1 + F \sin^2\left(\frac{\Delta\phi}{2}\right)}$$

**Finesse:**     $F = \frac{4R}{(1-R)^2}$

# Phase Modulated Fiber Optic Sensors

## ❖ Multi-beam fiber Interferometers

- Application of Fabry-Perot interferometers
  - Low finesse FP interferometers: widely used as sensors for mechanical parameter measurements (acoustic pressure, strain, displacement, vibration)

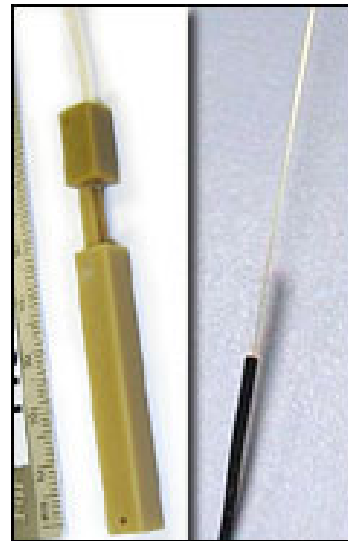
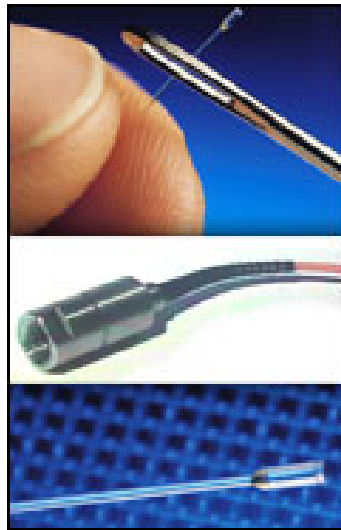

pressure and strain sensors from Fiso in Canada

# Phase Modulated Fiber Optic Sensors

## Strain Sensor

### Features:

Strain: 0 - 10,000  $\mu\epsilon$  / Unlimited

Resolution:  $< 1 \mu\epsilon$

Size: 250  $\mu\text{m}$  Diameter

Temp. Dependence:  $0.5 \mu\epsilon/^\circ\text{C}$

Temp. Range:  $-100^\circ\text{C} - 800^\circ\text{C}$

EMI Immune

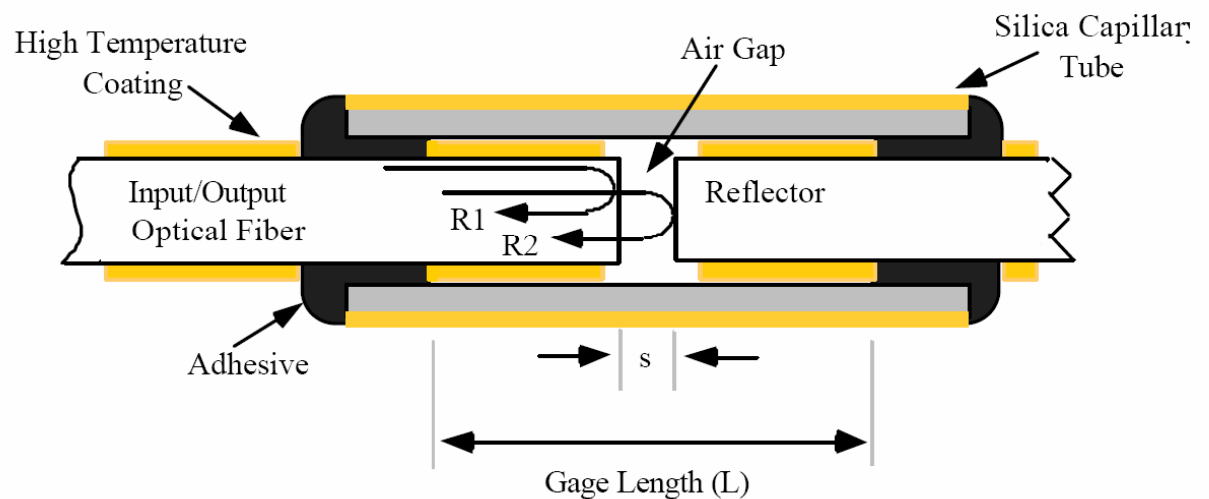

# Phase Modulated Fiber Optic Sensors

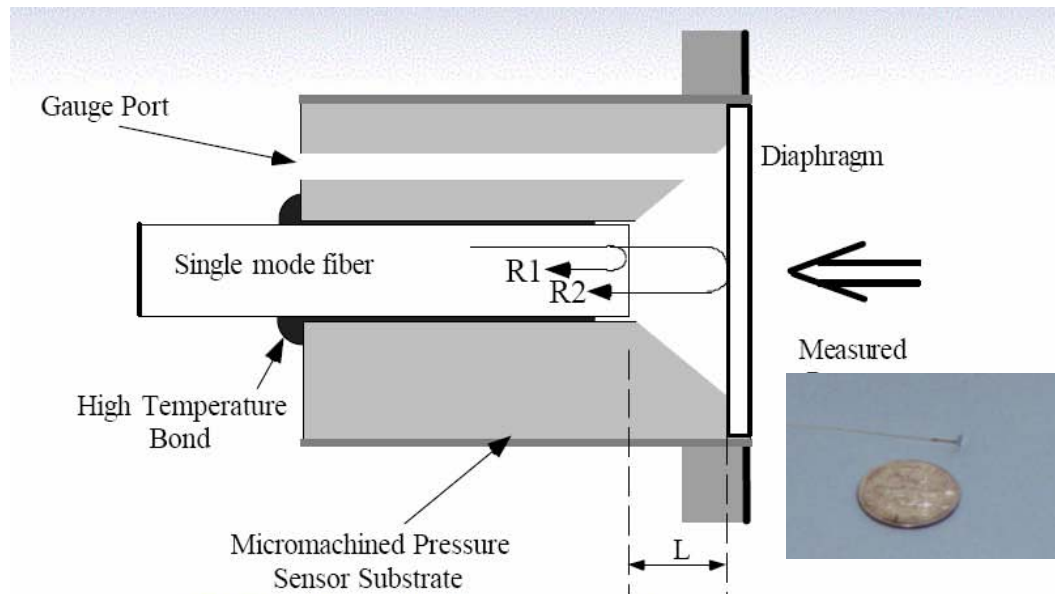

EFPI-Based Pressure Sensor

1-5 mm

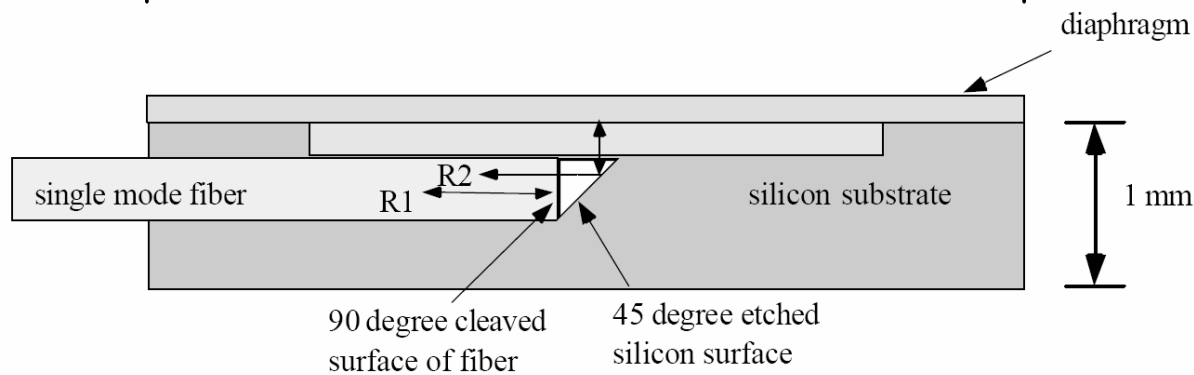

EFPI-Based Accelerometer

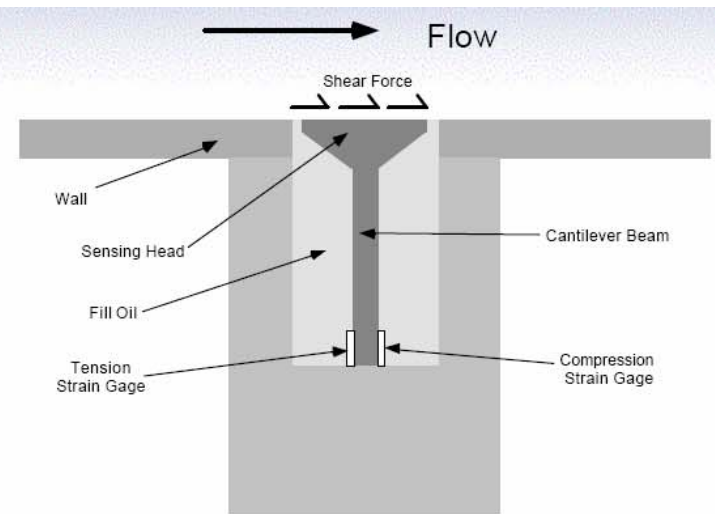

EFPI-Based Flow Sensor

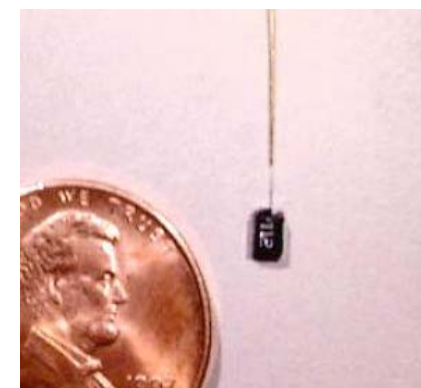

# Phase Modulated Fiber Optic Sensors

## ❖ Low coherence fiber-optic interferometer (LCFOI)

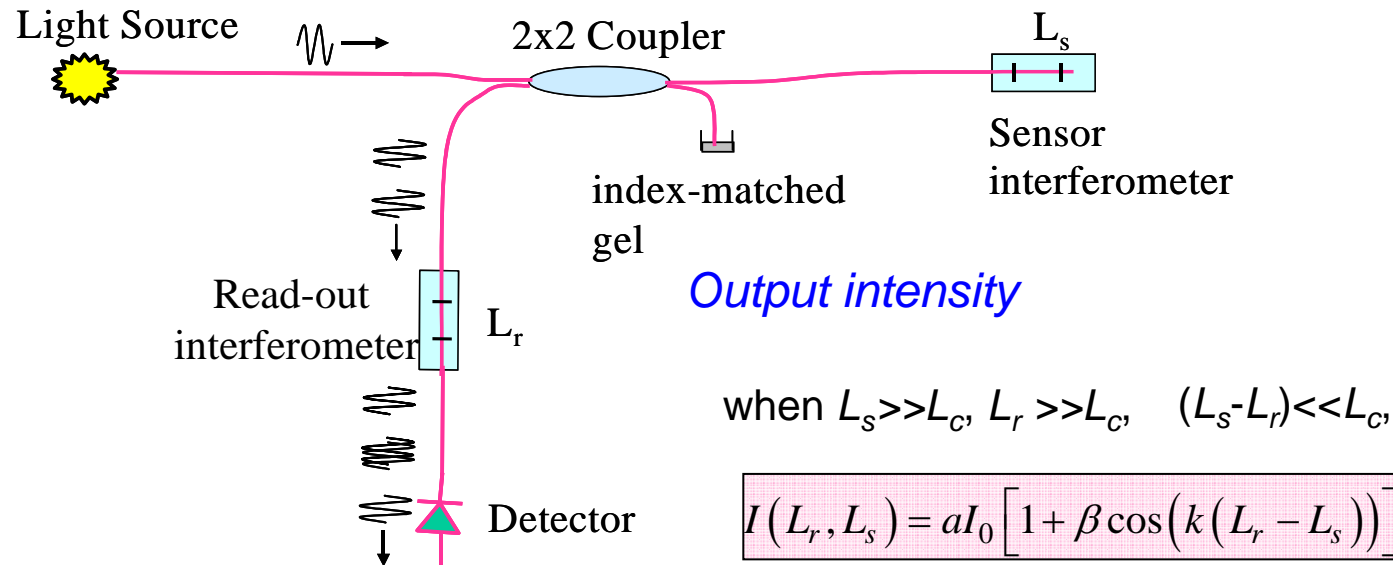

- Use a low coherence light source (SLD, LED, EDFA) to illuminate the system
- Have a sensing interferometer and a reference (read-out) interferometer, they can have either same configuration or different configuration
- Have much improved performance than conventional fiber optic interferometer based sensors

# Phase Modulated Fiber Optic Sensors

## ❖ Advantages of low coherence fiber-optic interferometry

- Phase change insensitive to wavelength fluctuation  $\delta\lambda$

$$\Delta\phi_{LCFOI} = \frac{2\pi(L_s - L_r)}{\lambda}$$

$$\Delta\phi_{conventional} = \frac{2\pi L_s}{\lambda}$$

$$\delta\Delta\phi_{LCFOI} = \frac{2\pi(L_s - L_r)\delta\lambda}{\lambda^2}$$

$$\delta\Delta\phi_{conventional} = \frac{2\pi L_s\delta\lambda}{\lambda^2}$$

- Short OPD and high resolution
- Large dynamic range

# Phase Modulated Fiber Optic Sensors

## ❖ Low coherence fiber-optic interferometer (LCFOI)

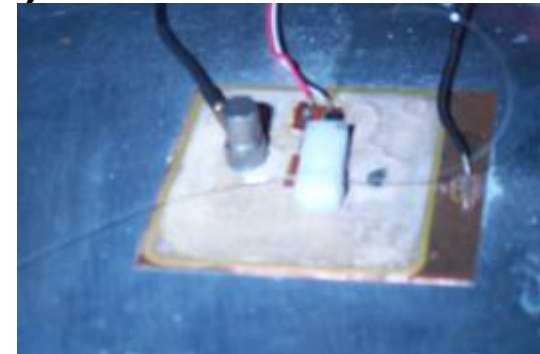
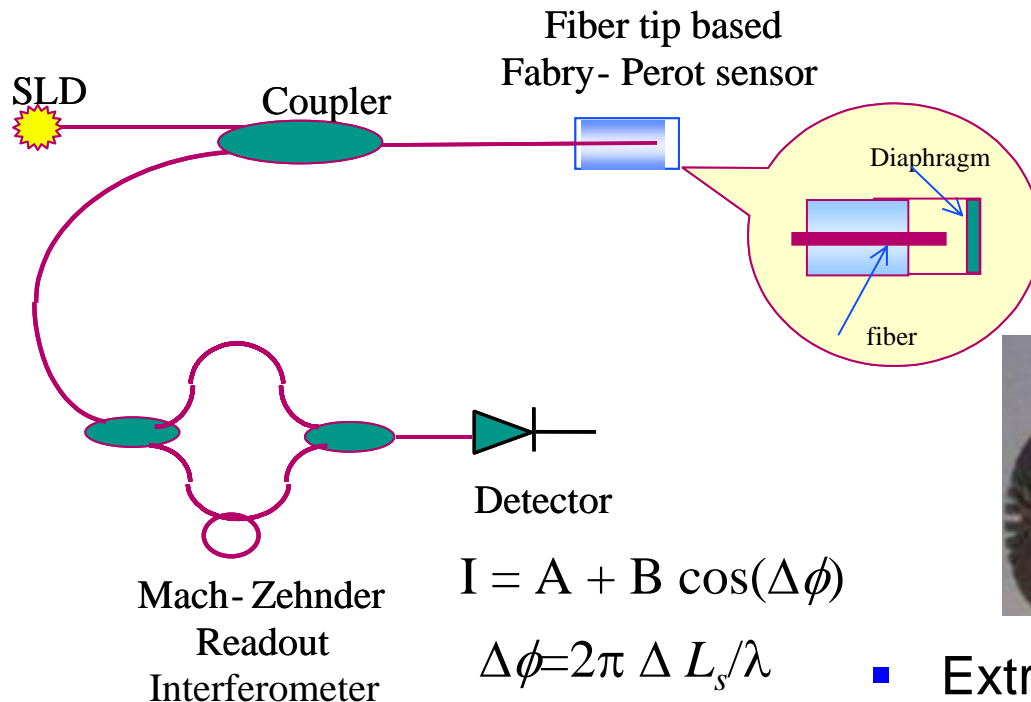

- Extrinsic sensor configuration
- Sound pressure induced diaphragm displacement change or vibration induced cantilever bending

# Phase Modulated Fiber Optic Sensors

## Low coherence interferometer based fiber optic Microphone



FTFP Mic. compared to Panasonic WM-54B Mic.



FTFP Mic. compared to Brüel and Kjaer 4134 Mic.

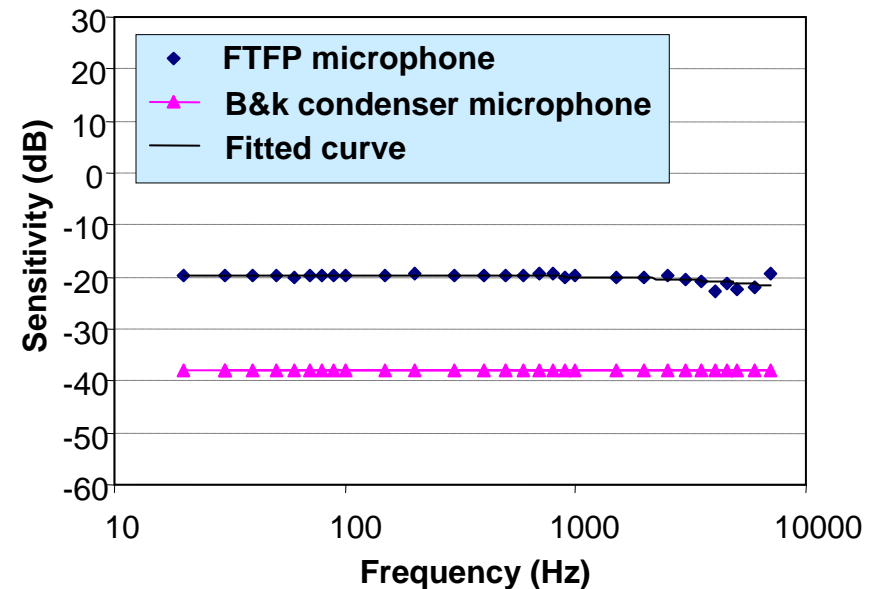
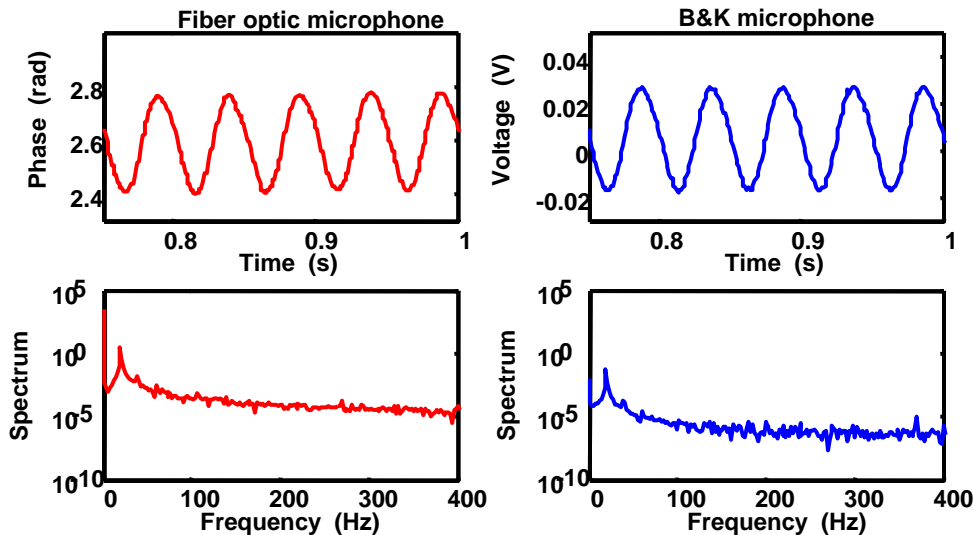

**U. S. Patent No. 6901176**

M. Yu and B. Balachandran, "Acoustic measurements using a fiber optic sensor system", *Journal of Intelligent Material Systems and Structures*, Vol. 14(7), pp. 409-414, 2003.

# Phase Modulated Fiber Optic Sensors

## Fiber Optic Accelerometer

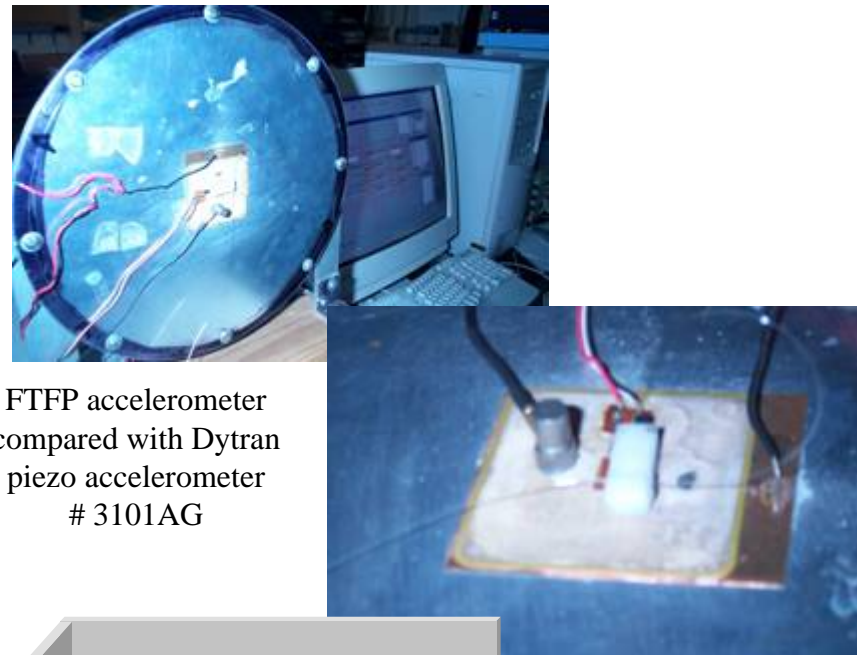

FTFP accelerometer compared with Dytran piezo accelerometer # 3101AG

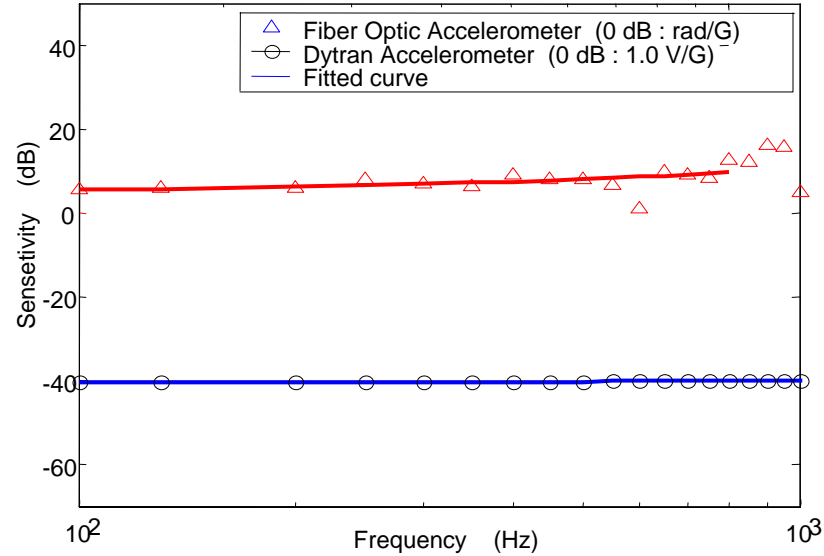
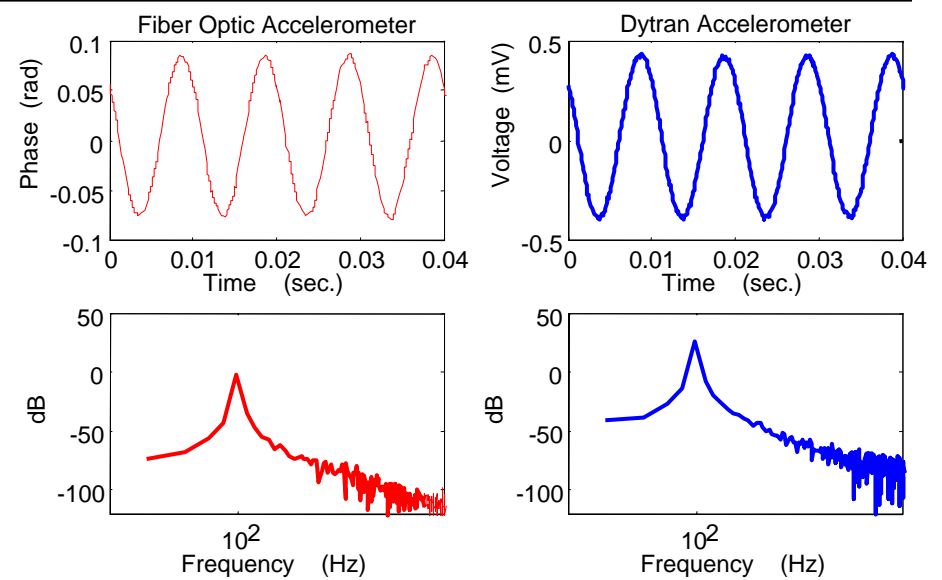

- ❖ **Beam:** Steel, 7.7 mm × 3.0 mm × 0.03 mm
- ❖ **Housing:** Delrin, 20.0 mm × 8.0 mm × 6.0 mm

M. Al-Bassyiouni, M. Yu, B. Balachandran and J. Oh, "Active acoustics control with fiber optic sensors," *Proceedings of SPIE 2002 Conference on Modeling, Signal Processing and Control*, Vol. 4693, Paper No. 4693--44, March 2002.



---

# Wavelength Modulated Fiber Optic Sensors

# Wavelength Modulated Fiber Optic Sensors

## ❖ What is a Fiber Bragg Grating (FBG)?

- Developed in 1978 by Canadian researchers Hill et al: photosensitivity of Ge-doped fiber
- A periodic change of the refractive index in the core region of an optical fiber.
- $\Lambda$  = pitch of the grating (period length)

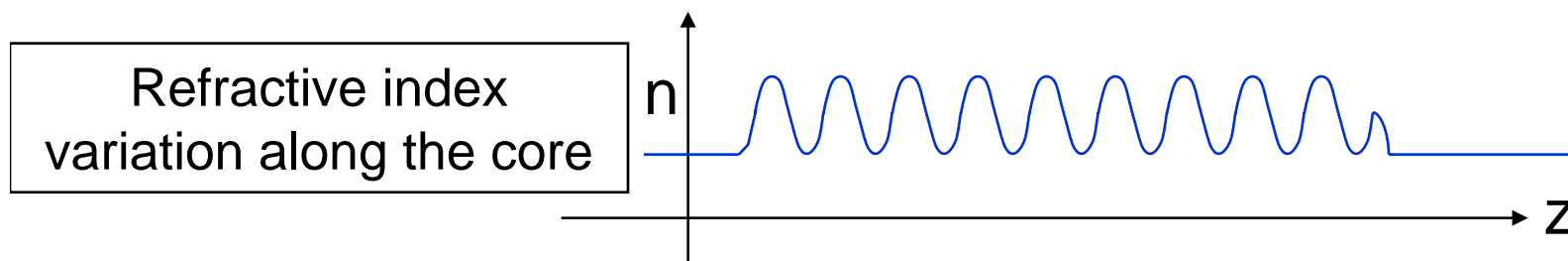
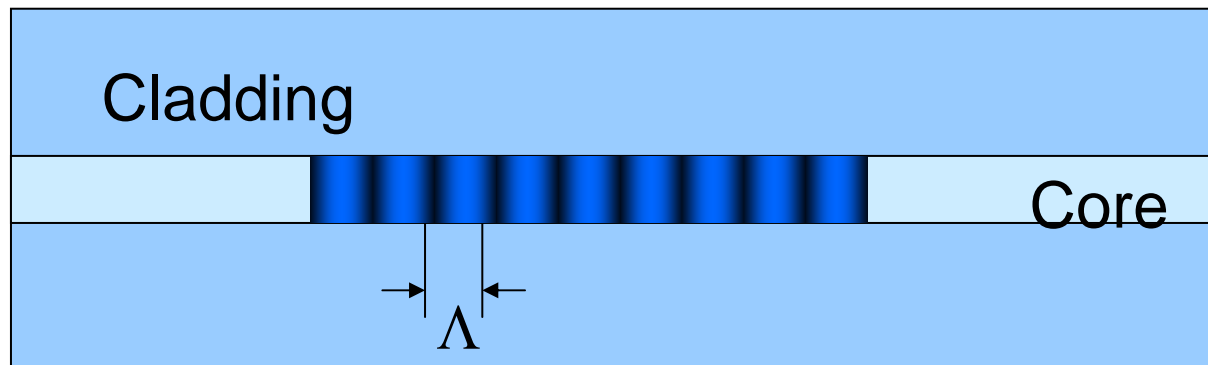

# Wavelength Modulated Fiber Optic Sensors



## ➤ The Bragg Condition

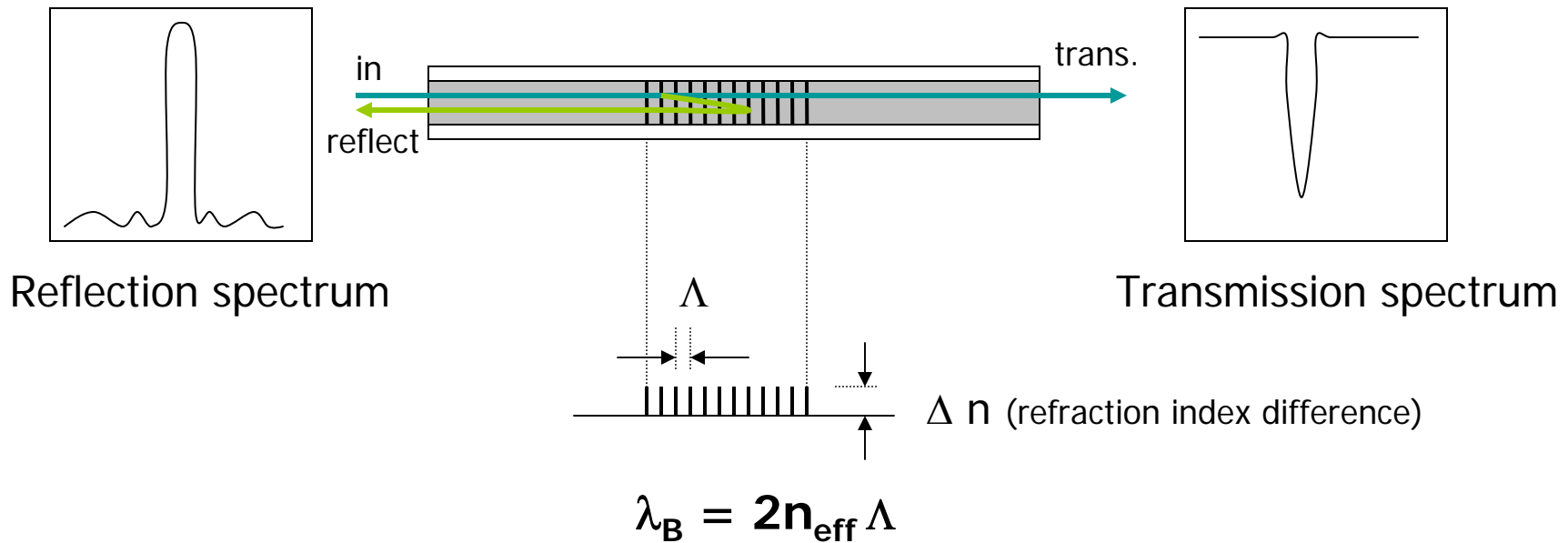

# Fiber Optic Sensor Systems: Fiber Bragg Grating Sensors



## ❖ Bragg grating sensors for strain and temperature measurements

Broadband Source

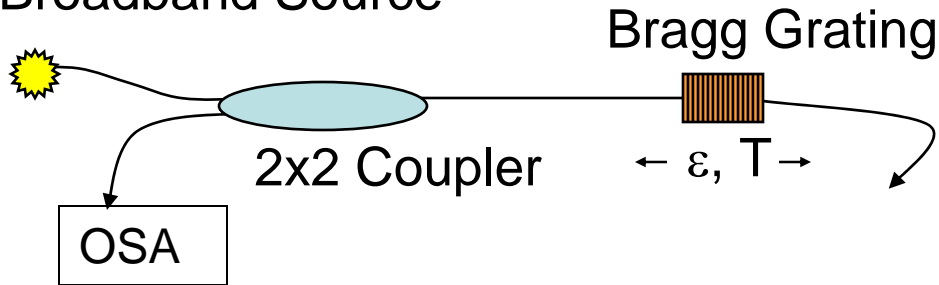

### ➤ Strain sensing

- Both  $\Delta\Lambda$  and  $\Delta n$  change
- Sensitivity:  $\sim 1.2 \text{ pm}/\mu\epsilon$
- Advantages over strain gauges

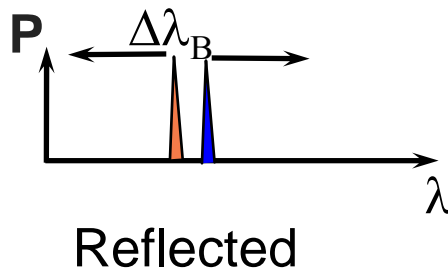

Bragg Wavelength  $\lambda_B = 2n\Lambda$

$$\Delta\lambda_B = 2n\Delta\Lambda + 2\Delta n\Lambda$$

### ➤ Temperature measurements

- Sensitivity:  $\sim 10 \text{ pm}/^\circ\text{C}$
- Especially useful for harsh environments (sapphire fiber)
- Temperature gradient

# Wavelength Modulated Fiber Optic Sensors

## ❖ FBG Sensors Demodulation

- Optical Spectrum Analyzer (OSA)
- Scanning
  - Filter
  - Swept laser
- Digital Spatial Wavelength Domain Multiplexing (DSWDM)
  - Spectral decoding

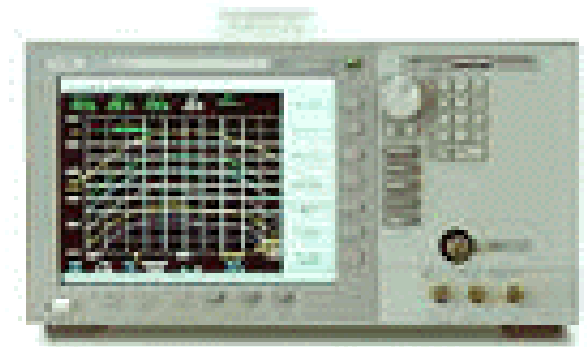

# Wavelength Modulated Fiber Optic Sensors

## ❖ Multiplexing of FBGs

- The ability to address multiple sensors using a single optical system
- Wavelength Domain
- Spatial Domain
- Time Domain
- Frequency Domain

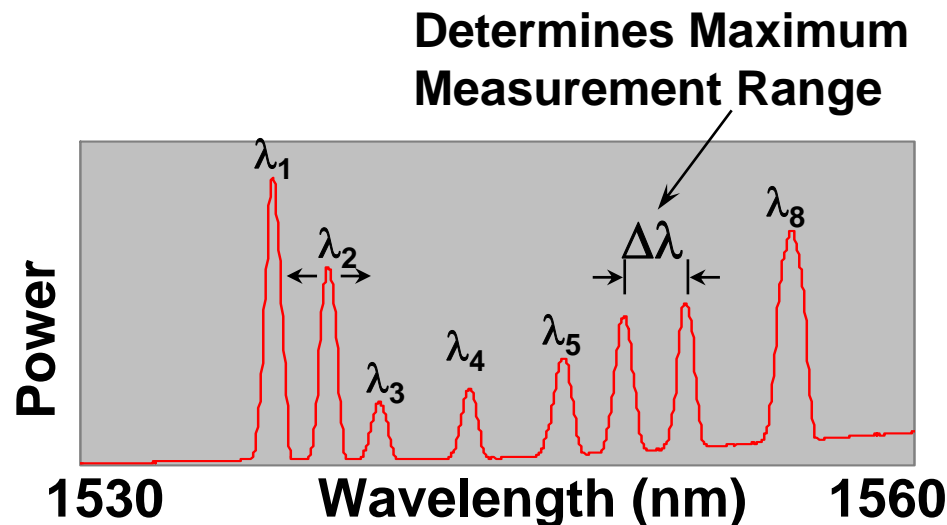
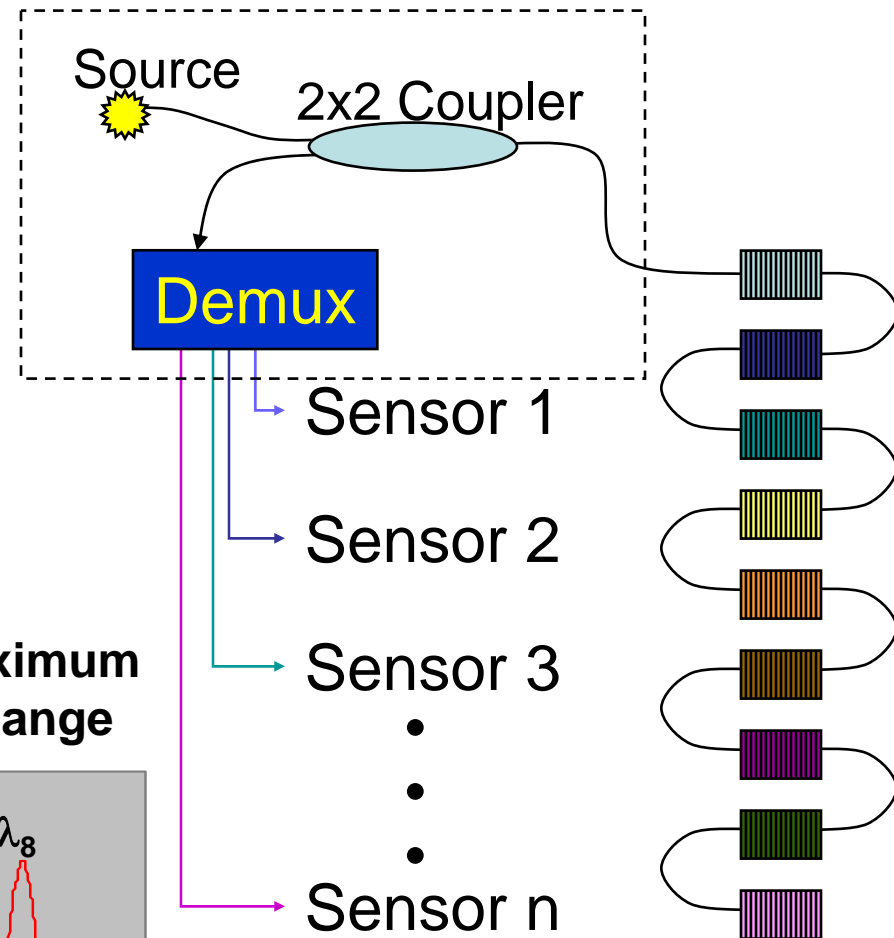

# Wavelength Modulated Fiber Optic Sensors

---

## ❖ Application areas

- Civil infrastructure
- Naval vessels
- Aircraft/space
- Oil and Gas
- Pipeline monitoring
- Electric Power and Transport
- Damage Assessment Systems

## ❖ Civil Applications

- Monitoring bridge structures
- Traffic flow/weight monitoring
- Cure of concrete
- Dam monitoring
- Earthquake monitoring
- Geotechnical Application
- Power generation/transportation
- Future – Corrosion of structures, wind sensing
- Fast growing field
- Many research groups are focused on these applications areas
- Mainly concerned with health monitoring

# Wavelength Modulated Fiber Optic Sensors



## Bridge Deck Supports

- ❖ To date, multiple bridges have been outfitted with fiber optic sensor monitoring systems
  - Majority FBG-based
- ❖ Monitor loads on the girders during the construction and over an extended period of time
- ❖ Blue Road Research outfitted Horse Tail Falls bridge with FBG's by placing sensor assemblies within the beams to monitor internal stresses of the bridge

Historic Horse Tail Falls Bridge,  
Oregon. Built 1922



Sensors Mounted onto Glass Epoxy



(Photos from Blue Road Research, [www.bluerr.com](http://www.bluerr.com))

# Wavelength Modulated Fiber Optic Sensors

(continued)

## Bridge Piles

- ❖ Embedded FBG Sensors
- ❖ Survivability of sensors throughout installation process

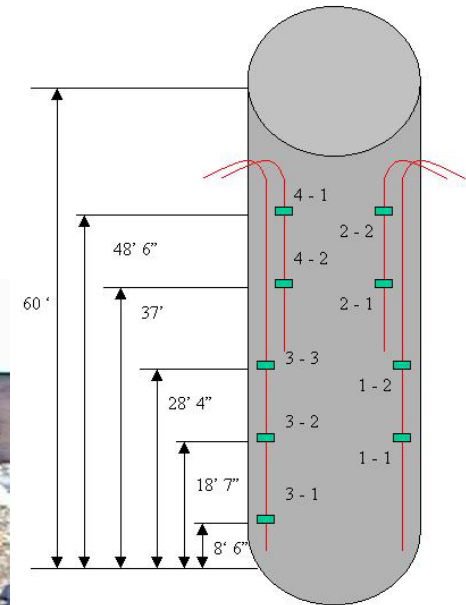
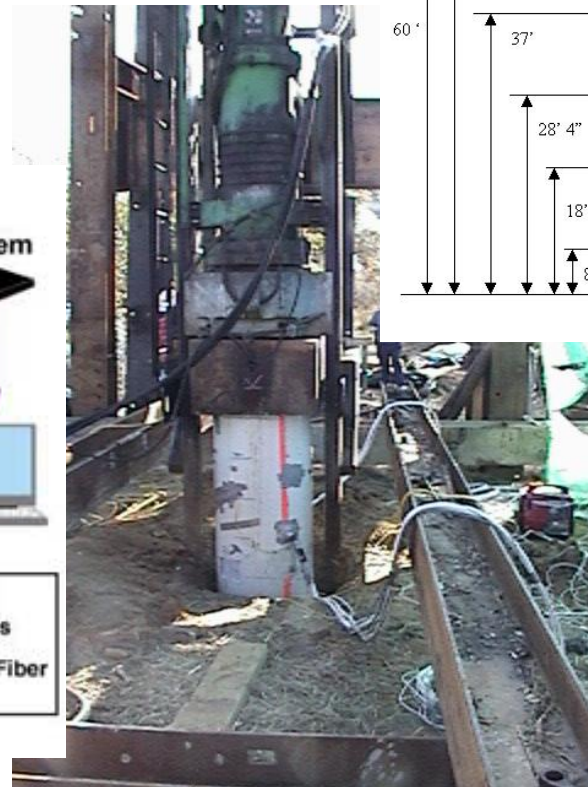
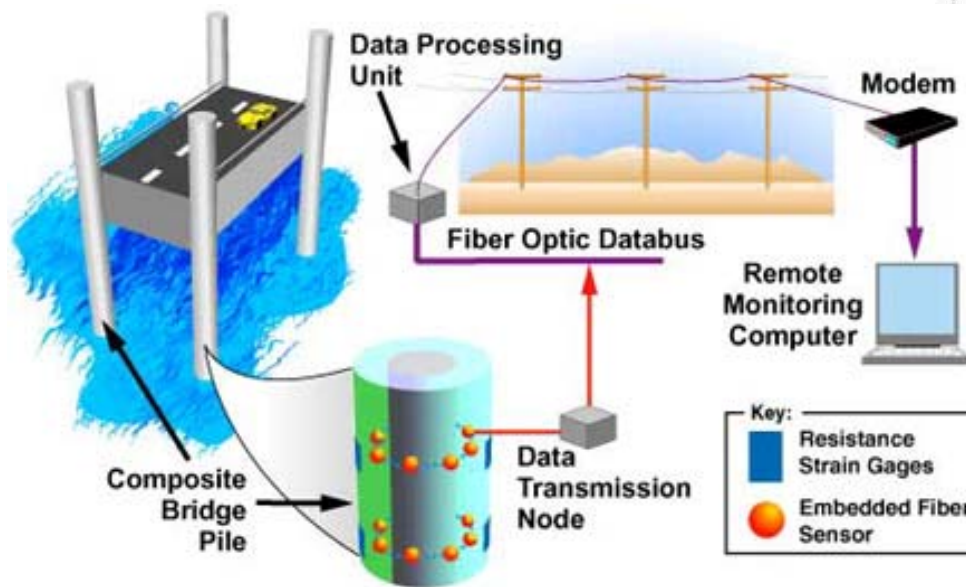

# Wavelength Modulated Fiber Optic Sensors



## Earthquake Monitoring of Structures

- ❖ Major topic in Japan
- ❖ FOS can evaluate remaining structures performance
- ❖ Monitor structural performance during an event
- ❖ Detect inelastic response of structural components
- ❖ Can be monitored remotely through internet
- ❖ Potentially increase building asset value

January 17, 1995 Kobe Japan, rating 6.9



(Photo from NGDC, [www.ngdc.gov](http://www.ngdc.gov))

# Wavelength Modulated Fiber Optic Sensors



## Traffic Monitoring

- ❖ Speed monitoring
- ❖ Weight sensing
- ❖ Traffic light sensing
- ❖ Future – Vehicle classification, weight in motion
- ❖ Combined with video cameras could allow specific vehicle identification

Traffic Across Bridge

Left to Right: Minivan, SUV,  
Car, Pedestrian

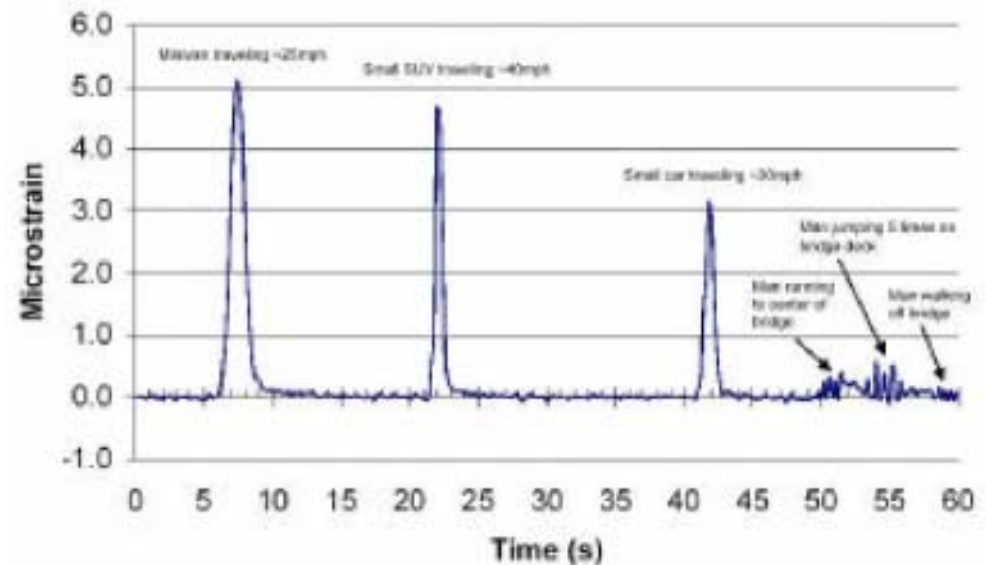

# Wavelength Modulated Fiber Optic Sensors

---

## Naval Applications

- ❖ Mainly dealing with ship structure monitoring
  - Norwegian fast boat
  - R/V Triton
  - Damage assessment
- ❖ Currently no cost effective method to monitor structural response of Navy ships
- ❖ Other application areas
  - Shape monitoring of towed sonar arrays
  - Submersible testing
  - Lock gate monitoring



# Wavelength Modulated Fiber Optic Sensors

## Shape Monitoring of Towed Sonar Arrays

- ❖ Currently, electronic sensors (heading and depth) are used to provide very rough estimates of sonar sensor locations
- ❖ FBG sensors can provide a more accurate method to define the shape of the array

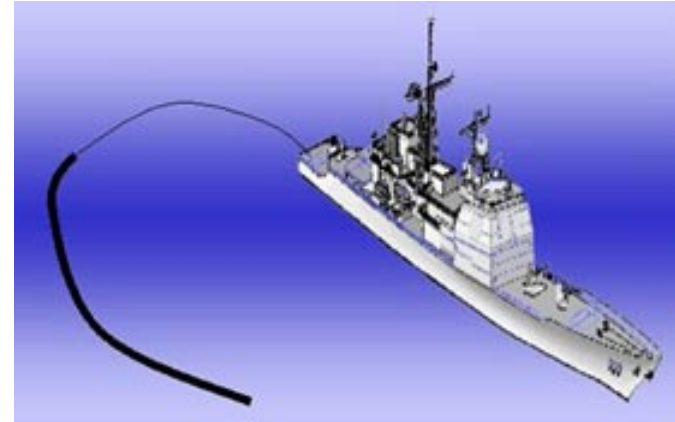

- ❖ This work also transitioning into other shape sensing applications including cables, oil risers, aircraft wings, electric power transmission lines, and the offshore drilling industry

# Wavelength Modulated Fiber Optic Sensors



## Shape Monitoring of Towed Sonar Arrays (continued)

240 ft hose equipped with 40 sensors, Error < 2in

- ❖ A strain-to-shape algorithm was developed that takes the embedded strain readings and determines the shape of the array along its entire length

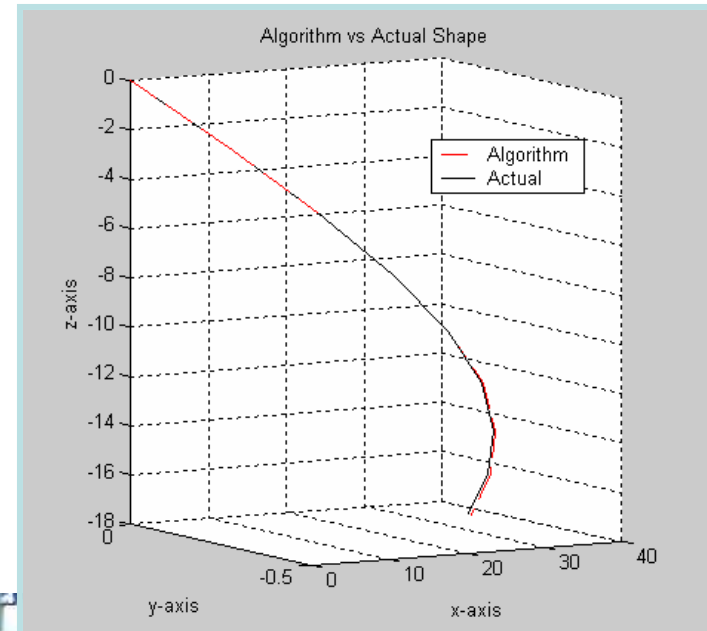

# Wavelength Modulated Fiber Optic Sensors

## Submersible Testing

- ❖ Measure strain on a deep diving submersible to depths of 1500 ft
- ❖ Fiber optic triaxial, biaxial, and uniaxial gauge locations
  - 97 FBG sensors

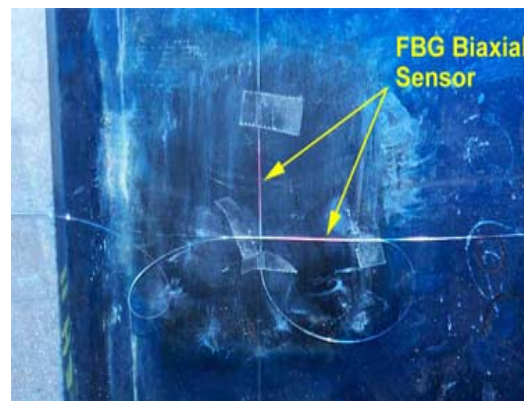

# Wavelength Modulated Fiber Optic Sensors

---

## Aerospace Applications

- ❖ Mainly dealing with aircraft structure and instrument monitoring
  - Wing Shape Design Analysis
  - Acoustic Crack Emission
  - Hydrogen Sensing



- ❖ Many systems on aircraft need careful monitoring - tail rotor loads, rotor/fuselage interaction, inboard rotor dynamics, hub aerodynamics, airfoil pressure, wake/tail interactions, fuel tank pressure, cryotanks, structural integrity, flight control systems as well as the position of landing gear, flap and rudders
- ❖ Maintenance and repair of military aircraft comprise more than 50% of total ownership costs

# Wavelength Modulated Fiber Optic Sensors

## Wing Shape

- ❖ Use fiber optic sensors to measure the deformation of the wing
  - Unmanned Aerial Vehicles
  - Smart Wing program

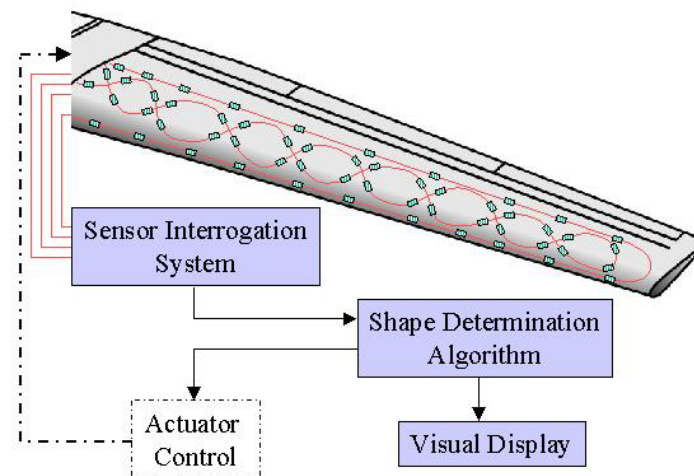

Push and Pull Loading of Plate based on Frenet Frame Matlab analysis with 12 Longitudinal Sensors

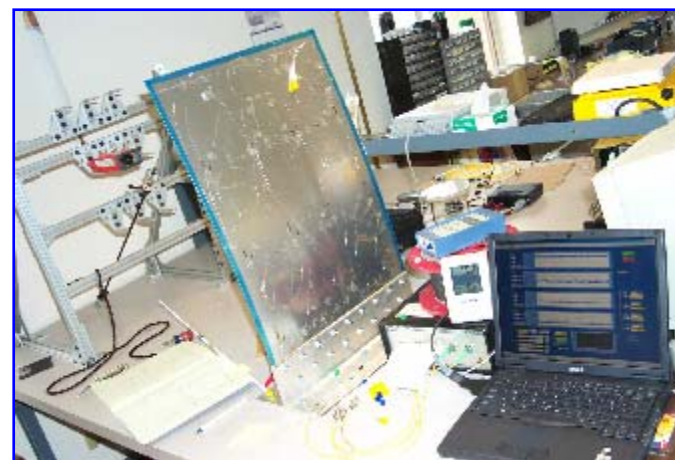
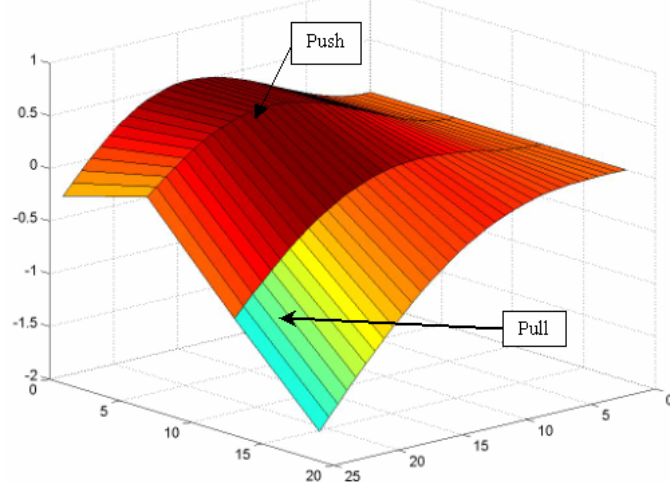

# Wavelength Modulated Fiber Optic Sensors



## Vertical Launch Systems

- ❖ Provide Long-term monitoring of the operating conditions of surface ship vertical launch systems and missiles
- ❖ Condition and Environmental Sensing and Reporting (CAESAR) program
- ❖ FBG sensors used to monitor
  - Temperature
  - Acceleration
  - Humidity
  - Strain
  - Pressure



# Wavelength Modulated Fiber Optic Sensors



## Hydrogen Sensing Onboard Space Shuttle Discovery

- ❖ NASA Langley has demonstrated the sensing of hydrogen using palladium coated FBGs on board the Space Shuttle Discovery on STS-96
- ❖ They used 20 gratings coated with Palladium tubes for hydrogen sensing and an extra 20 gratings within 1.5cm from the palladium for temperature compensation
- ❖ With this fiber optic network they could quantitatively detect hydrogen leaks in the aft bay of the orbiter during hydrogen tanking and vehicle ascent

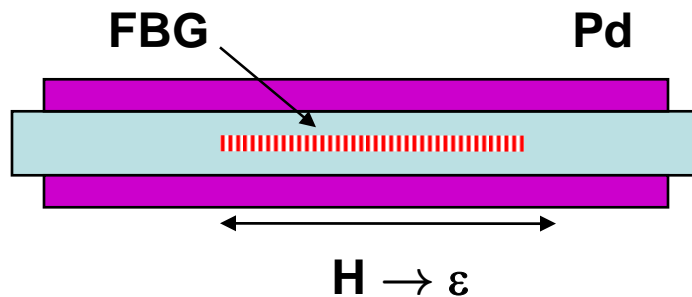



---

# Future Directions

# Fiber Optic Sensors: Future Directions

---



## ❖ Future Trends

- Special waveguides, such as photonic crystal fibers, will enable many new sensing mechanisms and sensor configurations
- Improved micro-fabrication technologies will continue to improve sensor performance, functionality, reliability and capability of harsh environment operation
- Advanced signal processing and network technology will enable high density fiber optic sensor networks