

LAN-XI

The Next Generation of Data Acquisition Systems

IMAC XXVIII
February 3rd, 2010
Jacksonville, Florida, USA

N-J. Jacobsen, Brüel & Kjær Sound & Vibration Measurement A/S

Content

- Data Acquisition Systems for S&V Measurements
 - Current Situation
 - Main Requirements to an Optimal Data Acquisition System
- The Philosophy and Technologies behind LAN-XI
 - One-cable Operation
 - » Power over Ethernet (PoE)
 - » Precision Time Protocol (PTP)
- Precision Engineering Technologies
 - Extended Dynamic Operating Range: Dyn-X
 - Response Equalisation: REq-X

Data Acquisition Systems: Current Situation

- Sound & vibration measurements are performed
 - On a wide range of structures
 - In different test environments
 - Under various operating conditions
 - Often under extreme time and cost constraints
- Accurate and reliable data acquisition is required
 - In a **quick** and **easy** manner regardless of whether the system is to be used in the **field**, in a **lab**, or in a **centralised** or **distributed** setup

A number of divergent requirements must be fulfilled

Consequently, data acquisition systems for sound & vibration measurements have up until now either been **optimised for dedicated use** or been the **result of a compromise**

Main Requirements to an Optimal DAS

Nature of Test Object - From smallest components to largest structures



From a few to hundreds of measurement channels
Scalable, modular and easily reconfigurable (plug & play)
Distributed sample synchronous front-ends

Test Environment – In-situ field or labs



Robustness, light weight, small, truly portable, low power consumption, battery operation
Distributed sample synchronous front-ends

Operating Conditions – Often Unknown and Uncontrollable Excitation



High dynamic range
Accurate measurements in a wide frequency range

Philosophy – One-Cable Operation

Same Standard LAN Cable used for

- Data Transfer
- Power Supply
- Sample & Phase Synchronisation

Made possible by new standardised technologies

- *PoE - Power over Ethernet - [IEEE 802.3af-2003](#) (Update [IEEE 802.3-2005](#))*
- *PTP - Precision Time Protocol - [IEEE 1588-2002](#) (Update [IEEE 1588-2008](#))*

PoE - Power over Ethernet

- A technology that allows power to be transmitted along with measurement data on a LAN cable in an Ethernet network from Power Source Equipment (PSE) to Powered Devices (PDs)
- Voltage level: 36 – 57 V (usually 48 V); Current: Max. 400 mA
- Power Class 0 (default): 0.44 – 12.95 W at Powered Device (PD)

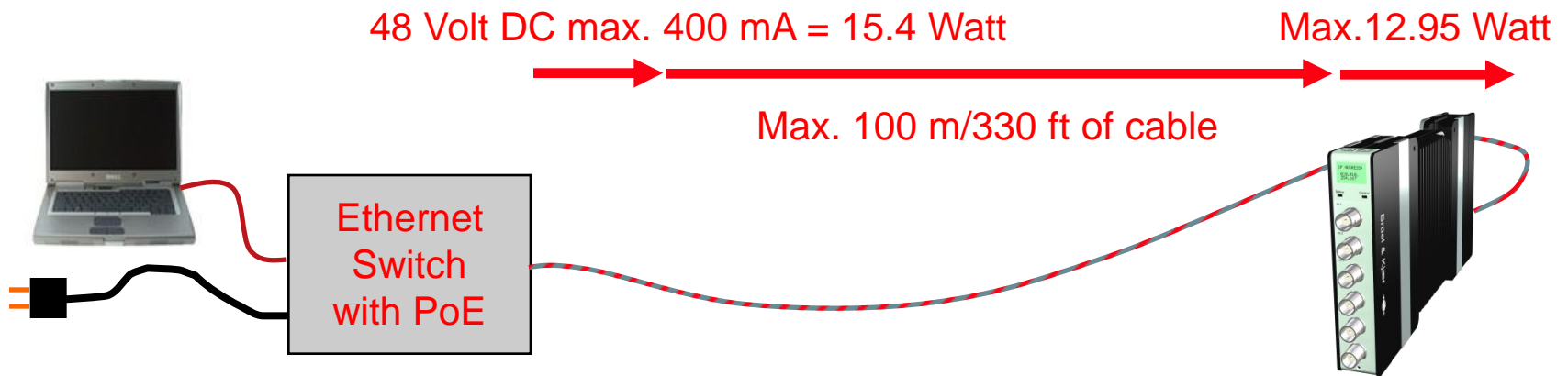

PoE Device Terms

- There are two types of Power Source Equipment (PSE)
 - 1: **“Endspans”** ... Ethernet switches with built-in power injectors
 - 2: **“Midspans”** ... Ethernet switches with separate power injectors

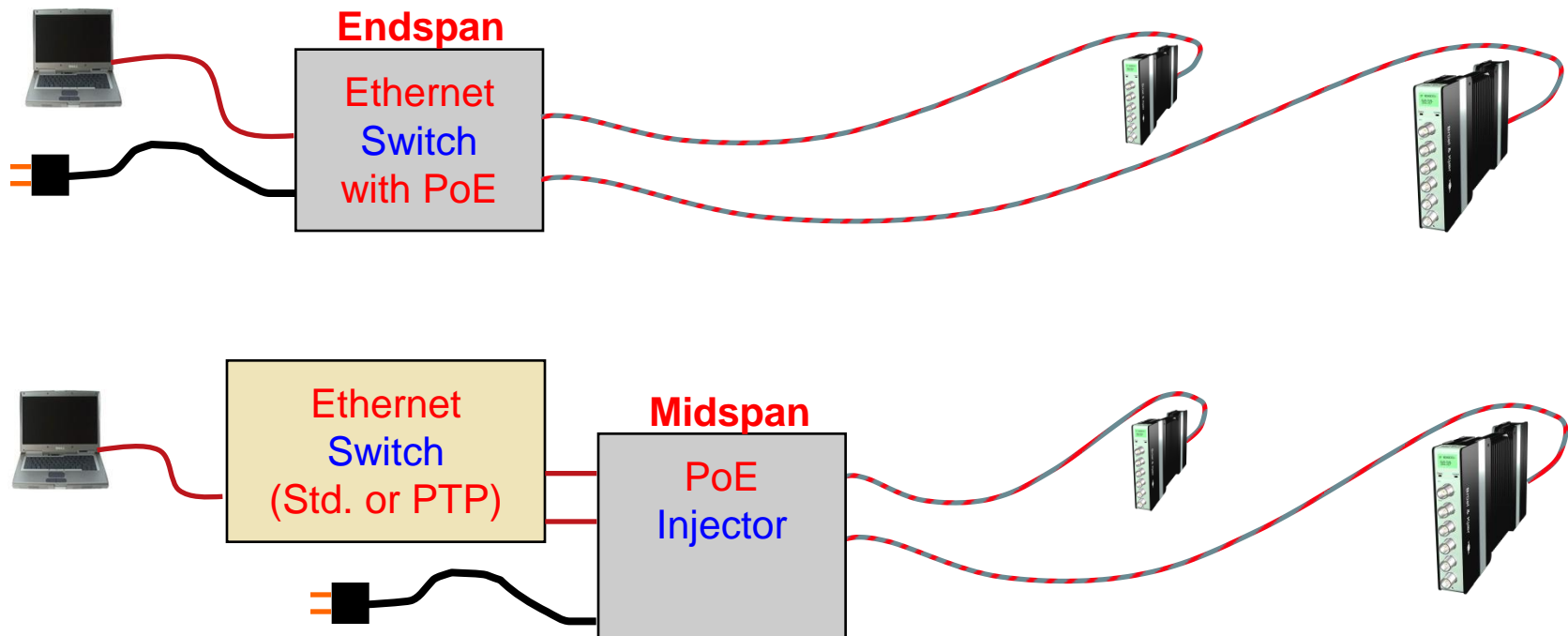

PoE - Detecting Mode and Power Classes

PD indicates power required by placing a “Signature Resistance” (19 – 26.5 kΩ) and Signature Capacitance (150 nF) between powering pairs.

PSE turns off power if $15\text{k}\Omega > \text{Signature resistance} > 33\text{k}\Omega$; Signature capacitance $> 10\ \mu\text{F}$

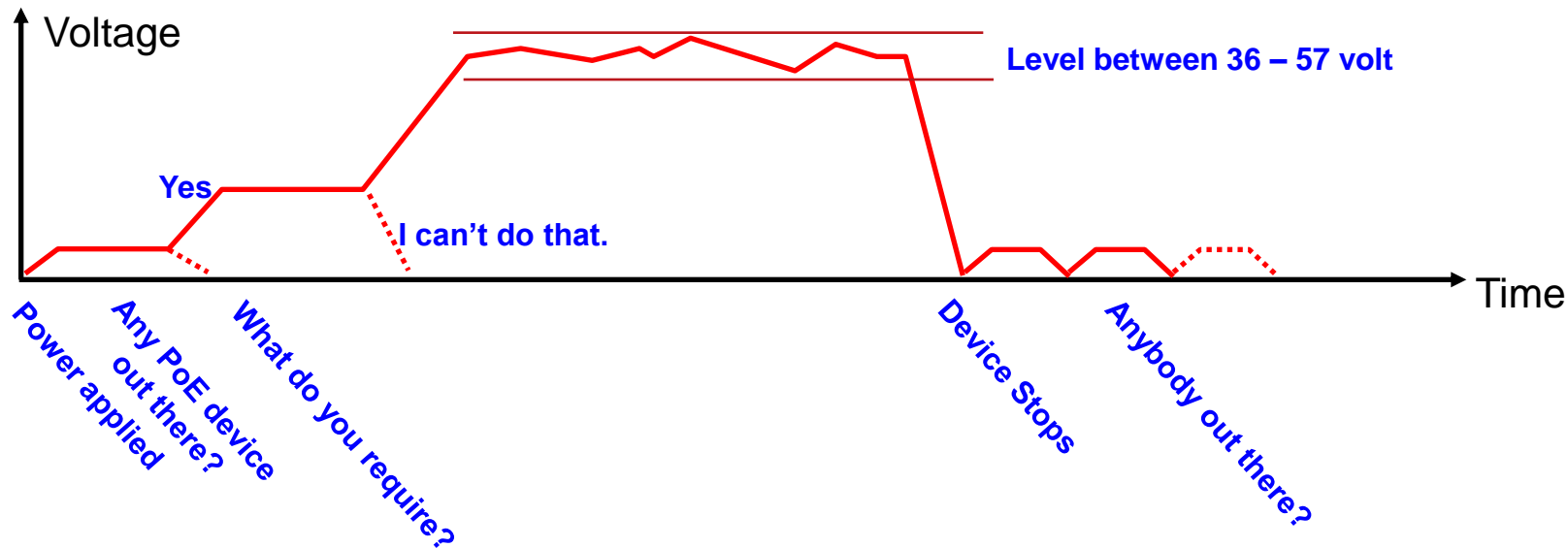

Power Class	Usage	Input Power Level [W]
0	Default	0.44 – 12.95
1	Optional	0.44 – 3.84
2	Optional	3.84 – 6.49
3	Optional	6.49 – 12.95
4	Reserved for future use	-

Why Sample Synchronisation and PTP?

- Most Sound & Vibration applications require a very accurate phase between the measurement channels
- Rule of thumb:
 - Phase match $< \pm 300 \text{ ns}$: $\pm 3^\circ @ 25.6 \text{ kHz} \sim \pm 1^\circ @ 10 \text{ kHz} \sim \pm 0.1^\circ @ 1 \text{ kHz}$
- A sample synchronisation method is required
 - All individual sampled systems will in less than **one second** drift apart not fulfilling the above requirements
 - Very high quality sampling crystals accuracy $\pm 2 \text{ ppm}$ -> $\pm 2 \mu\text{s drift/s}$ -> $\pm 18^\circ/\text{s} @ 25.6 \text{ kHz} \sim \pm 7^\circ/\text{s} @ 10 \text{ kHz}$
- LAN-XI PTP synchronisation error between modules and frames
 - Standard 1 Gigabit switch: $< \pm 200 \text{ ns}$ ($\sim \pm 2^\circ @ 25.6 \text{ kHz}$)
 - Dedicated PTP switch performance is improved by a factor 10 ($\sim \pm 0.2^\circ @ 25.6 \text{ kHz}$)

LAN-XI PTP synchronisation is unique as no extra cables are required!
This allows the individual modules to be in phase with long distance in-between!

PTP - Performance Example

Measurement made with two individual LAN-XI modules interconnected with 170m (2*85m) between them

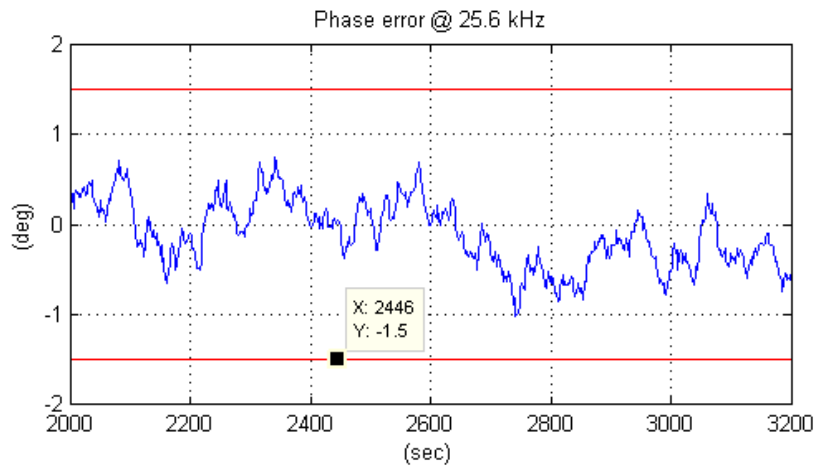

Performance using a **standard LAN switch**
< 1 degree

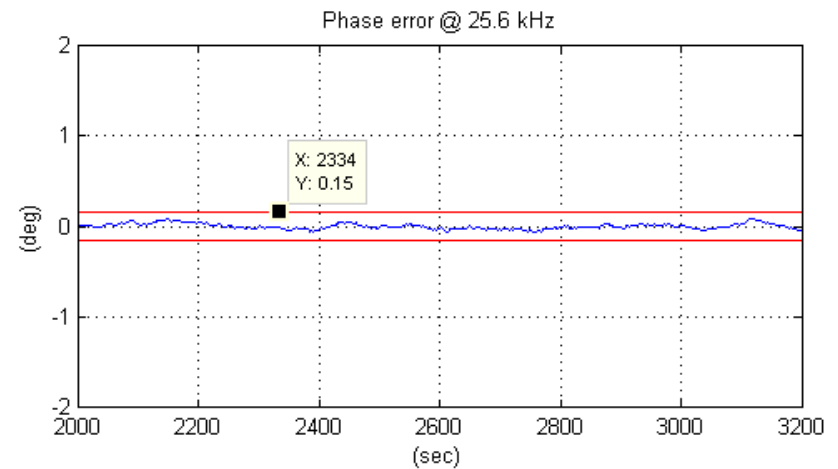

Performance using a **IEEE 1588 LAN switch**
< 0.15 degree

Basic Principle of Time Synchronisation

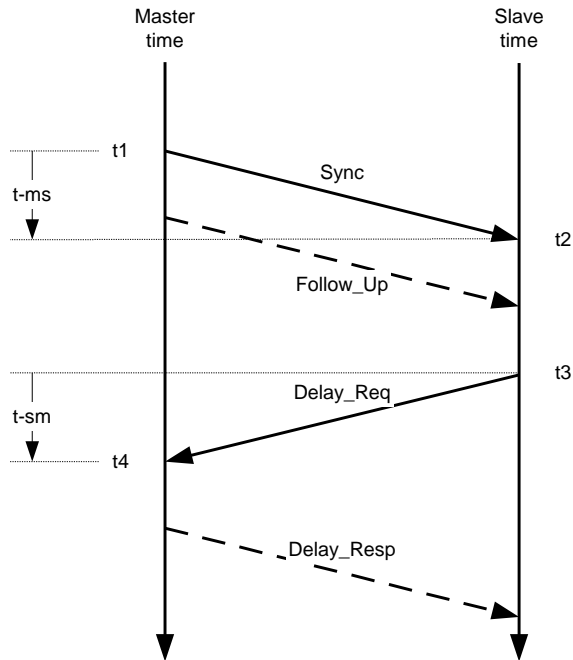

Time Stamping (Hardware)

$$t_{\text{msdiff}} = t_2 - t_1 = t_{\text{ms}} + t_{\text{offset}}$$

$$t_{\text{smdiff}} = t_4 - t_3 = t_{\text{sm}} - t_{\text{offset}}$$

Re-arranging

$$t_{\text{offset}} = ((t_{\text{msdiff}} - t_{\text{smdiff}}) - (t_{\text{ms}} - t_{\text{sm}})) / 2$$

$$t_{\text{ms}} + t_{\text{sm}} = t_{\text{msdiff}} + t_{\text{smdiff}}$$

Assumption

$$t_{\text{ms}} = t_{\text{sm}} = t_{\text{onewaydelay}}$$

Result

$$t_{\text{offset}} = (t_{\text{msdiff}} - t_{\text{smdiff}}) / 2$$

$$t_{\text{onewaydelay}} = (t_{\text{ms}} + t_{\text{sm}}) / 2$$

In addition to the PtP synchronisation

The LAN-XI concept also corrects for the unavoidable phase shifts of the Slave clocks by continuously measuring and counter-adjusting the Slave clocks

Transducer Hub - Distributed Modules!

- PoE + PTP
- LAN as a data backbone

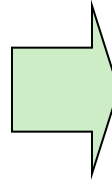

- Distributed system
- One cable operation

A new measurement situation!

- Move closer to the measurement object!
- Fewer & shorter transducer cables –use inexpensive LAN cable
- Short transducer cables = Better measurement quality!
- Less setup and measurement errors
- Less maintenance

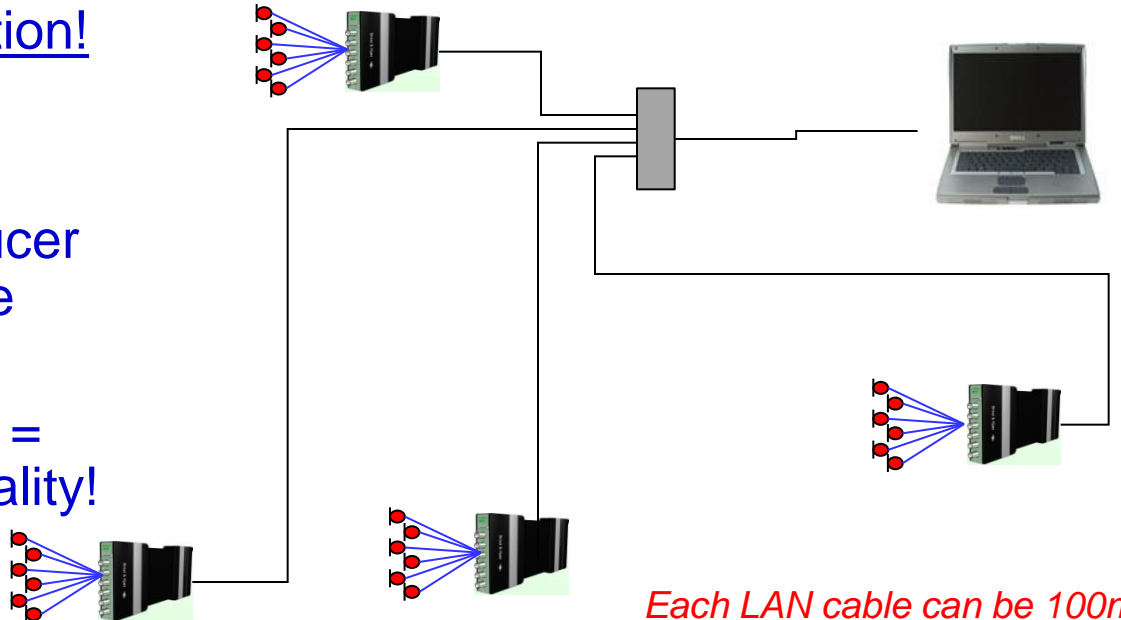

Reduced Complexity using Distributed System

A Traditional Measurement System - Complexity!

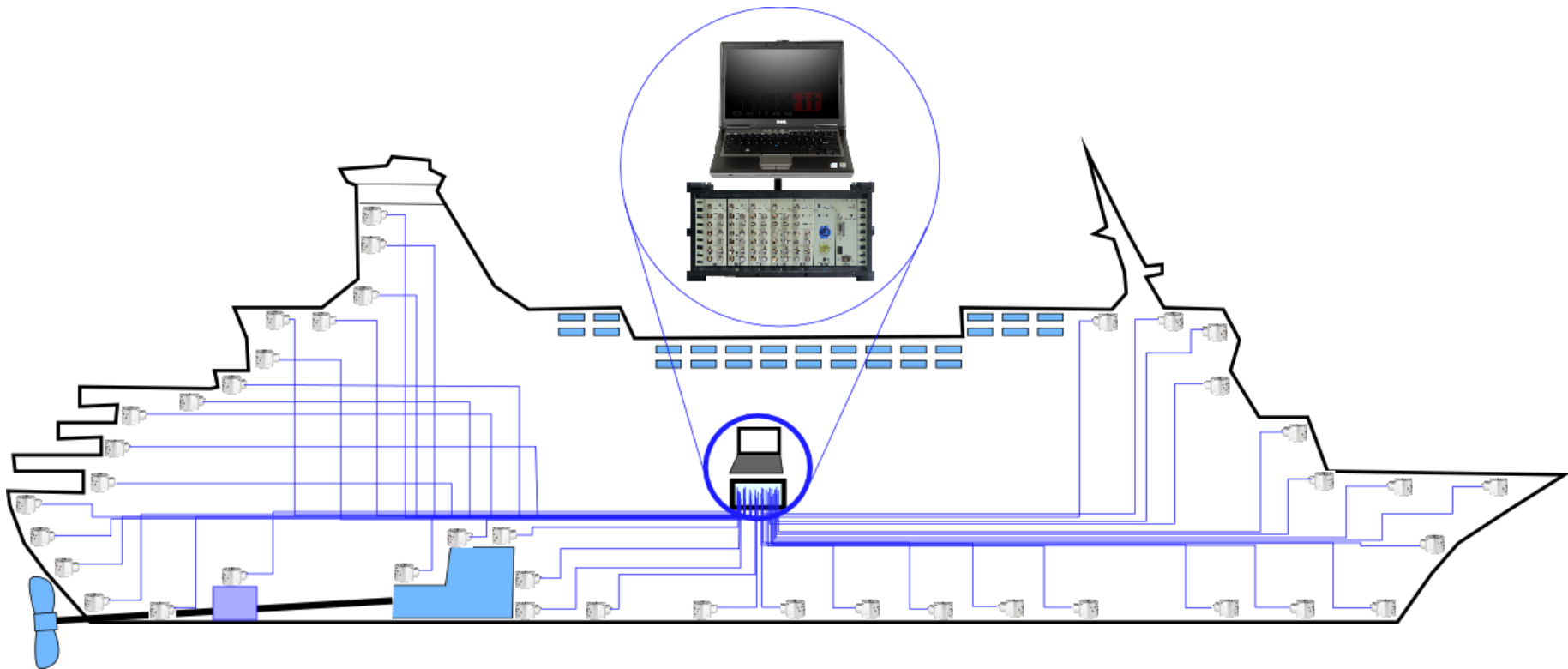

Reduced Complexity using Distributed System

A LAN-XI Distributed System - Simplicity!

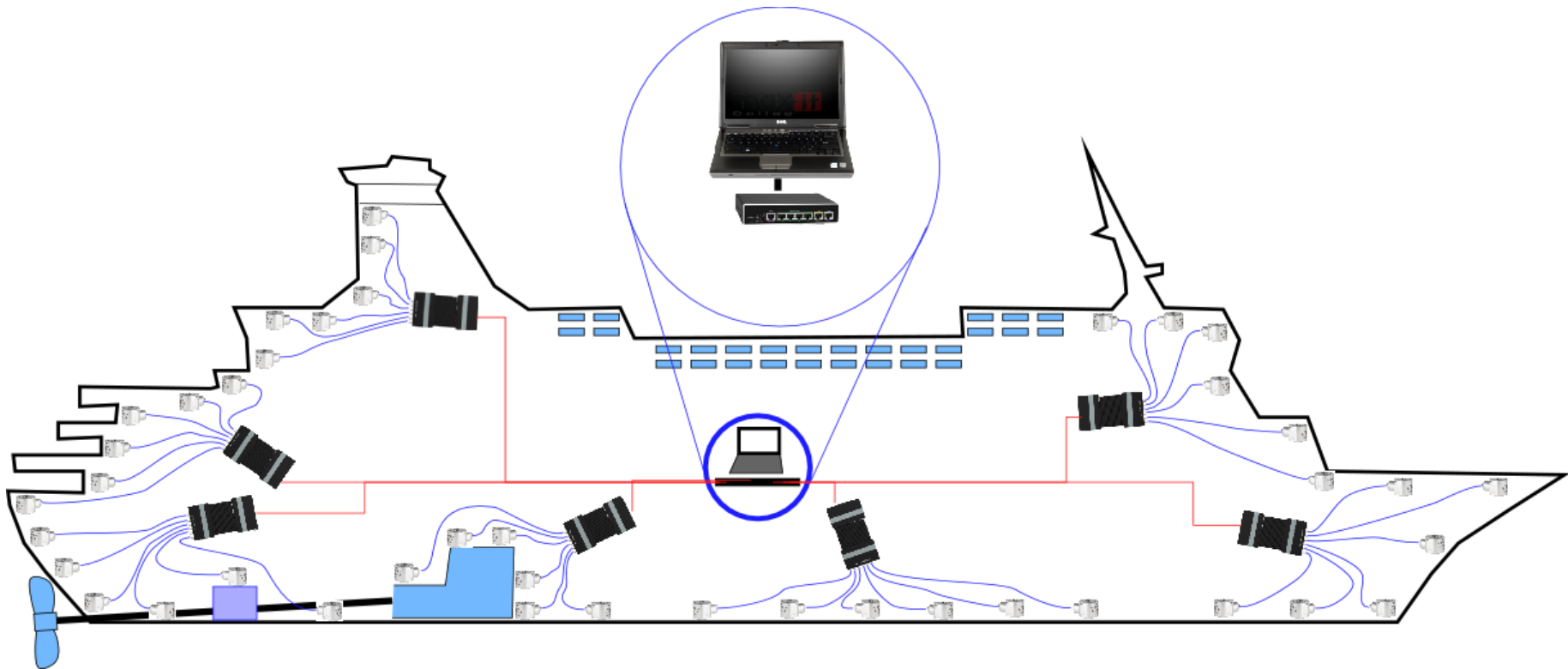

Test Cell Infra-Structure

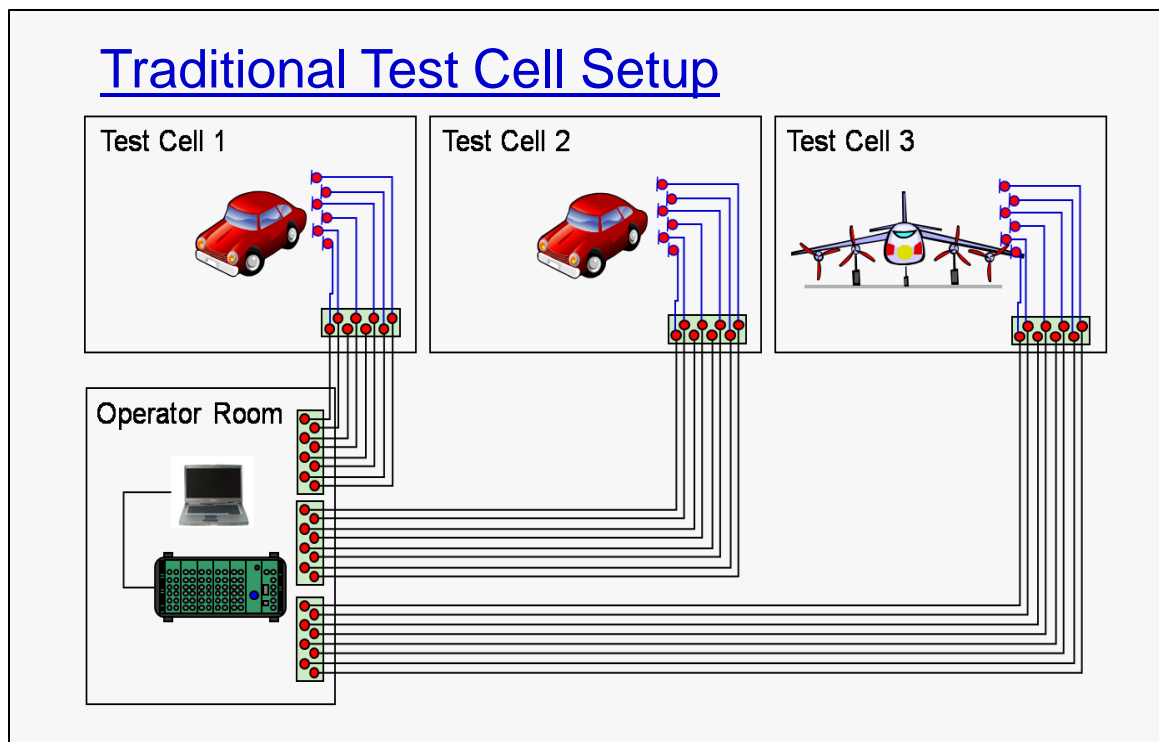

Test Cell Infra-Structure

Traditional Test Cell Setup

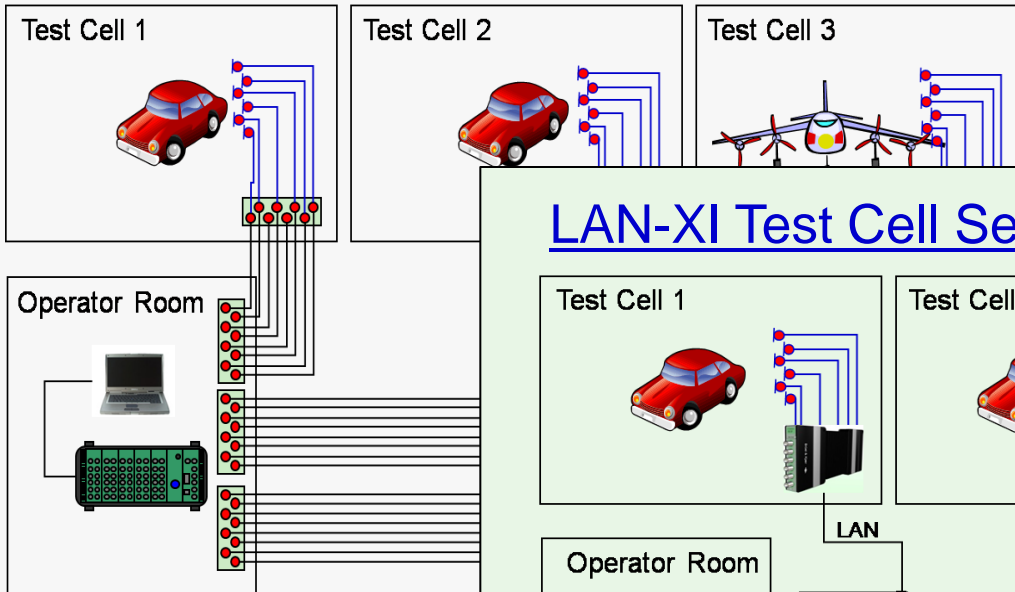

LAN-XI Test Cell Setup

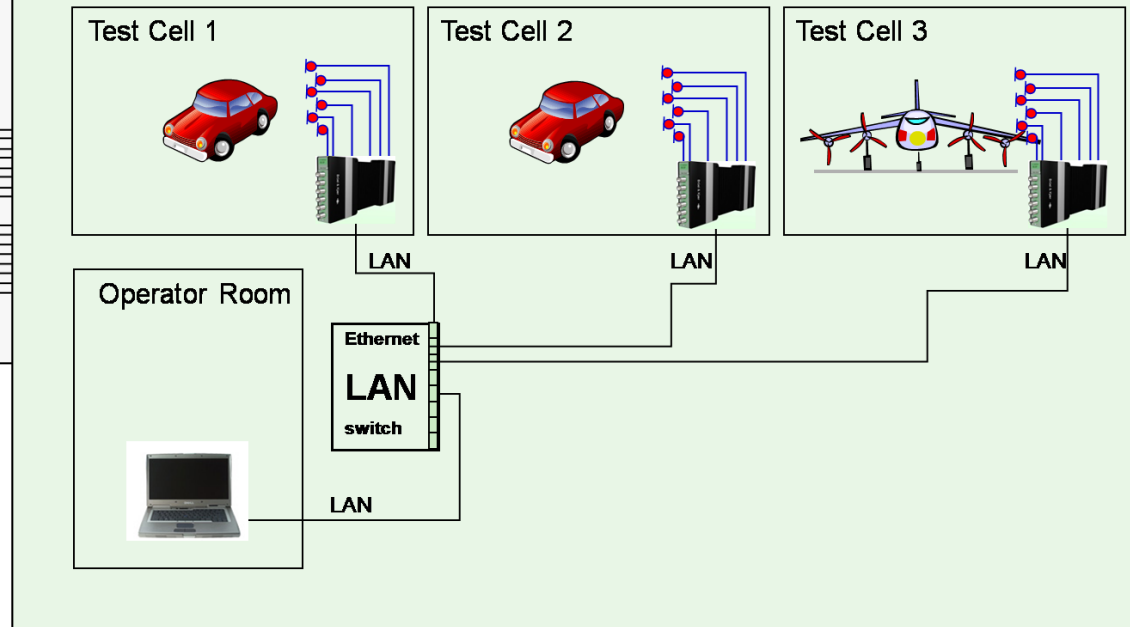

Dynamic Range of Transducers and ADCs

Acquisition performance over the last 30 -40 years!

Range: 25.6 kHz

Dynamic range of Deltatron®/IEPE transducers:

- 3 μV to 5 V ~ 124 dB

Dynamic range of high-quality ADCs:

- 1970 ~ 60 dB (10-12 Bit)
- 1980 ~ 70 dB (14-16 Bit)
- 1990 ~ 80 dB (16 Bit)
- 2000 ~ 100 dB (24 Bit)
- 2010 ~ 110 dB (24 Bit)

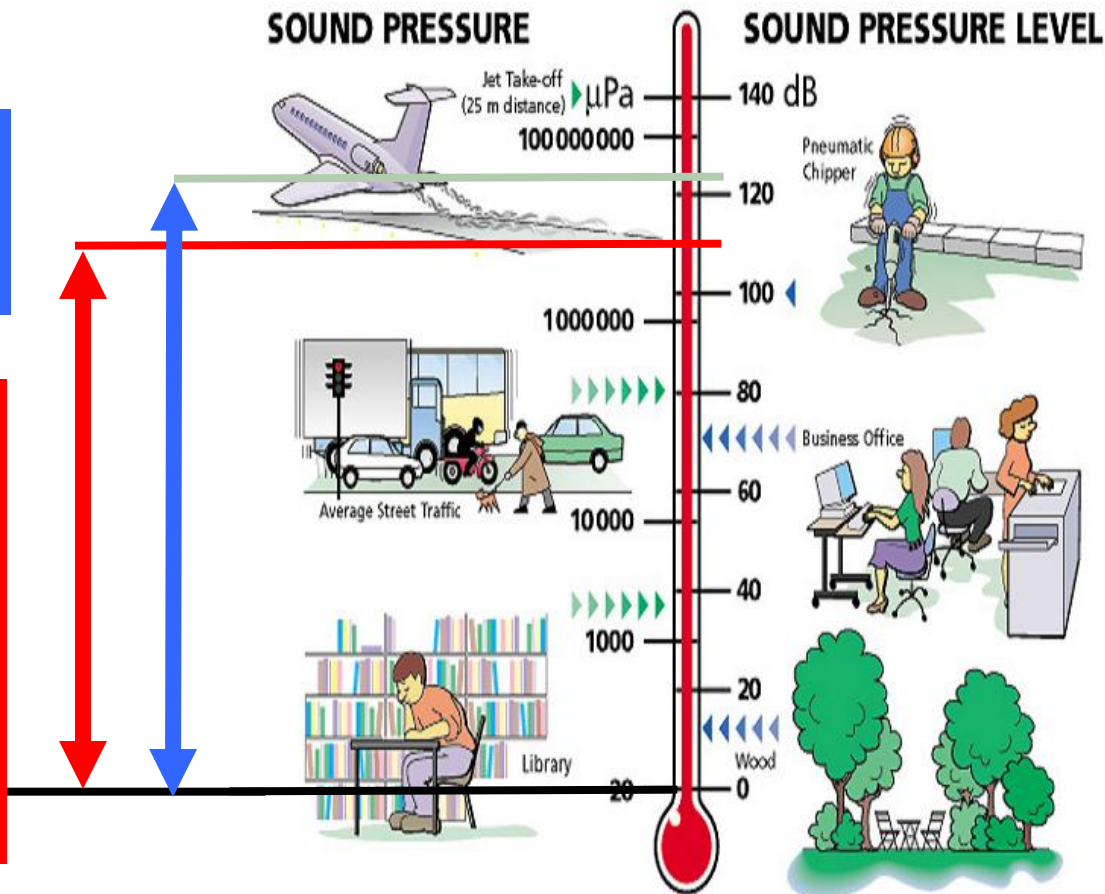

Dyn-X Technology – 160 dB in one range!

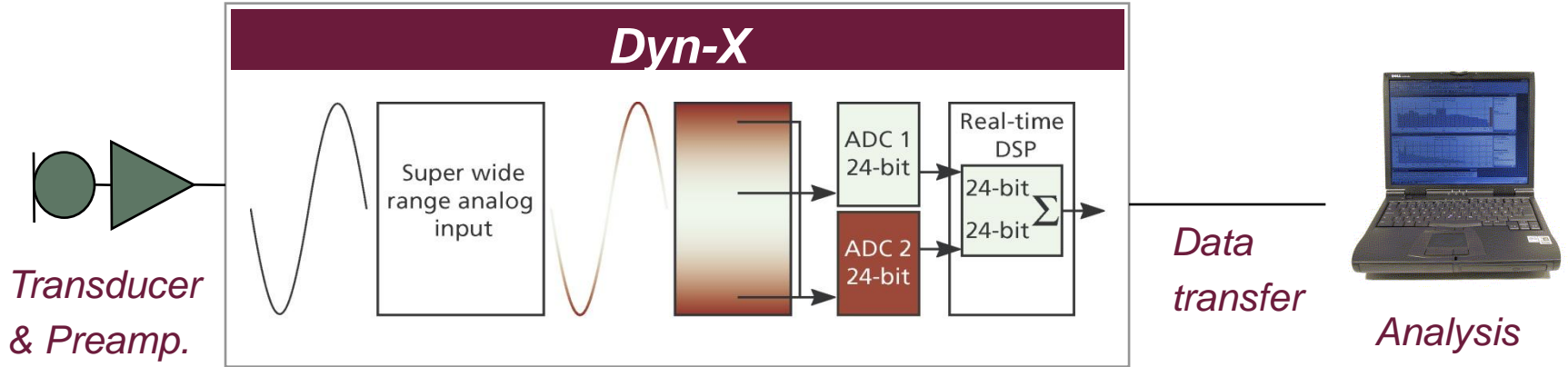

Simplified block diagram of Dyn-X input channel

Dynamic range for complete analysis chain:

- 125 dB Broadband Lin (10 Hz – 25.6 kHz)
- 161 dB Narrowband Lin (6 Hz BW e.g. 25.6 kHz FFT with 6400 lines and Hanning weighting)
- Real-time correction of:
Gain, phase and offset errors

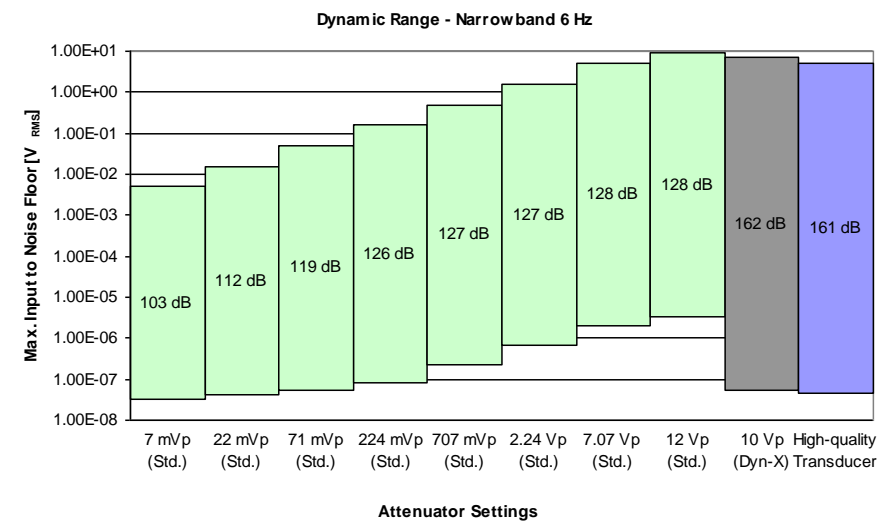

No more trial runs, repeated measurements, overloads and under range situations!

REq-X - Response Equalisation – eXtreme

Basic Principle

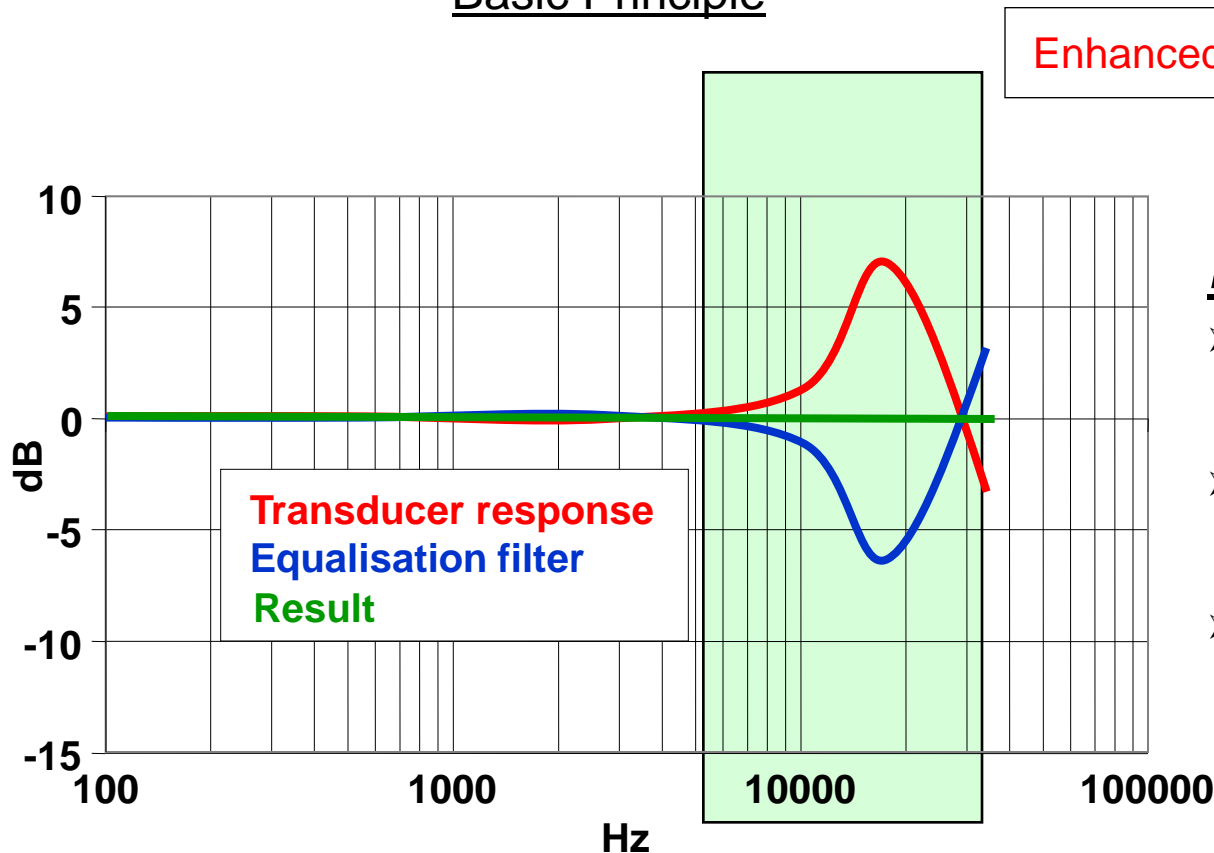

REq-X

- *Expands* the use of existing transducers
- *Improves* the accuracy of the measurement
- *Extends* the frequency range of transducers

REq-X can be used for both **amplitude** and **phase** equalisation

Time-domain implementation (**real-time**)

REq-X – Accelerometer Example

Measurement example – Type 4507 mounted with metal clip

Resonance frequency = 19 kHz → *Standard rule "Use up $0.3 * F_s$ " = 5.7kHz*

Actual +10% (1 dB) at 7.0 kHz without REq-X

With REq-X → *New Standard rule "Use up $0.5 * F_s$ " = 9.5kHz*

Actual +10% (1 dB) at 12.0 kHz with REq-X

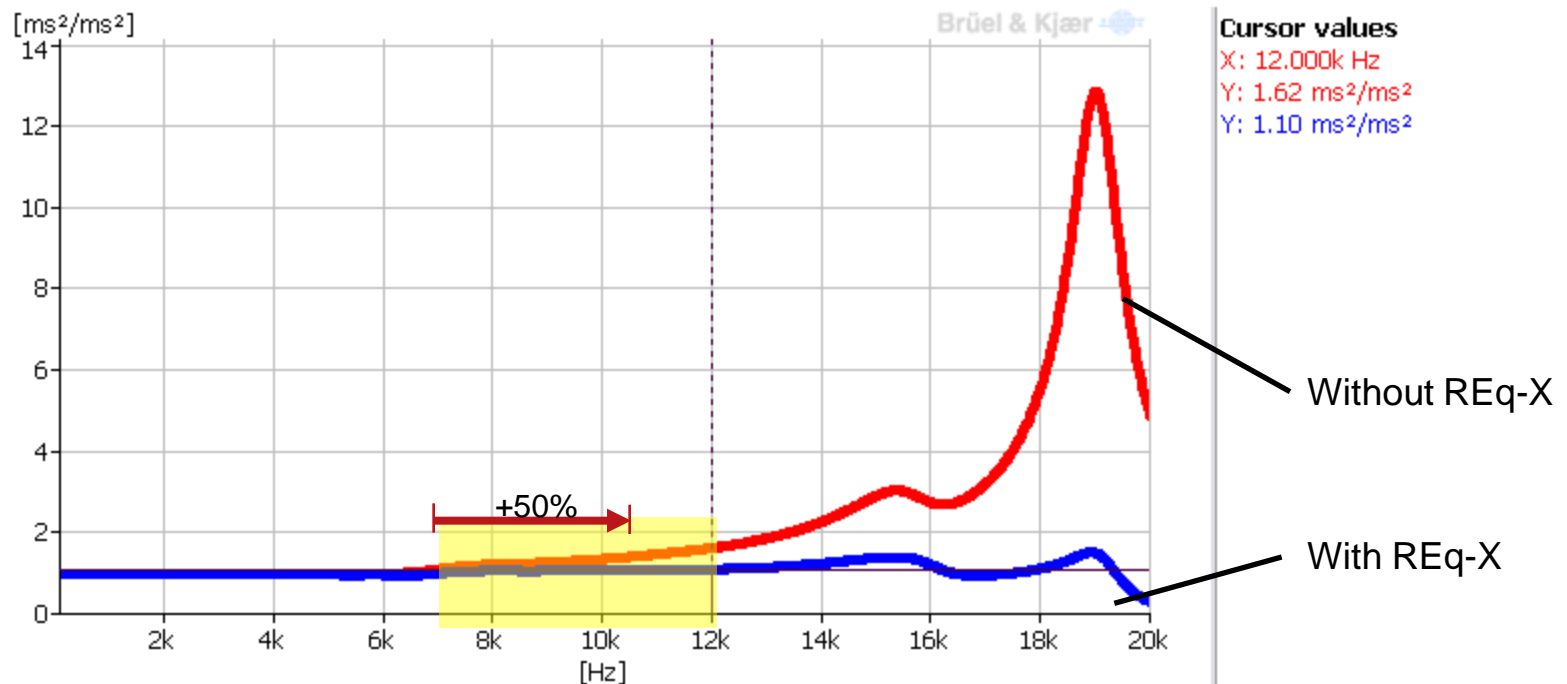

Conclusion

Standard technologies ***Power over Ethernet (PoE)*** and ***Precision Time Protocol (PTP)*** allow use of the same ***standard LAN cable*** for power supply, data transfer and sample synchronisation (***one-cable operation***).

The same data acquisition system can now easily be configured from 2 to more than ***1000 channels*** and can be used in a ***centralised*** or ***distributed setup*** either in the ***field*** or in a ***lab***.

Benefits include:

- Significant cost savings on transducer cables
- Significant reduction in setup and maintenance time
- Reduced risk of setup and measurement mistakes
- Less measurement noise

Dyn-X and ***REq-X*** technologies – with ***TEDS support*** - add true ***Plug & Play*** functionality and ensure ***high-quality measurements first time***.